

Spare parts catalogue with prices



TUNZE[®]

**High-Tech
Aquarium Ecology**



English

2010/2011



0091.000_E

4025167009112

TUNZE Aquarientechnik GmbH
Seeshaupter Str. 68 • D82374 Penzberg
Tel. 0049 8856 2022
Fax 0049 8856 2021
www.tunze.com

Nominal charge € 2,00
02/2010

Content

Designation	Page
Spare parts illustrations _____	3 - 26
Turbelle® powerhead / electronic _____	3
Turbelle® Maintenance instructions _____	4 - 5
Turbelle® electronic < 2000 _____	6
Turbelle® Maintenance instructions < 2000 _____	7 - 9
Turbelle® stream old model _____	10
Wavebox _____	11
Turbelle® nanostream® / stream _____	12
Turbelle® classic 2002 / 4002 _____	13
Comline Filter _____	14
Comline DOC Skimmer _____	15
Classic DOC Skimmer _____	16
Nano DOC Skimmer / Nano cleaner / Nano pump _____	17
Automatic skimmer < 2004 _____	18 - 19
Comline Automatic skimmer <2004 _____	20-21
Comline Calcium Automat _____	22
Osmolator Universal _____	22
Turbelle® stream II > 2008 _____	23
TUNZE SYSTEM _____	24-25
Kogapur _____	26
Total price list _____	27- 32

Turbelle® powerhead / electronic

600/2 1000/2 1600/2 3000/2

600/2 - 1000/2 - 1600/2 - 3000/2

	0600/2	1000/2	1600/2	3000/2	Ersatzteilliste Turbelle® powerhead/electronic	List of spare parts for Turbelle® powerhead/electronic	Liste des pièces Turbelle® powerhead/ electronic
1	0600.015	1000.015	1600.015	3000.015	Motorblock	Motor block	Bloc moteur
2	3000.020	3000.020	3000.020	3000.020	O-Ring, 78x2,5mm	O-ring seal, 78x2,5mm	Joint torique, 78x2,5mm
3	3000.600	3000.600	3000.600	3000.600	Antriebseinheit	Drive unit	Equipage mobile
4	0602.120	1002.120	1500.120	3000.120	Kreisel	Impeller	Rotor
5	0700.130	1500.130	1500.130	3000.130	Kreiselgehäuse	Impeller housing	Carter du rotor
5a		1002.150			Reduzierstück	Reducer	Réduction
6	1001.770	4002.770	4002.770	4002.770	Strömungswinkel	Flow deflector	Déflecteur de flux
7	3000.780	3000.780	3000.780	3000.780	Muffe ø25/28mm	Bushing ø25/28mm	Manchon ø25/28mm
8	0104.790	0104.790			Schlitzkörper, 7cm	Strainer, 7cm (2.7 in.)	Crépine, 7cm
8a			1001.790	1001.790	Schlitzkörper, 12cm	Strainer, 12 cm	Crépine, 12cm
9	3000.250	3000.250	3000.250	3000.250	Turbelle®-Halter	Turbelle® holder	Support Turbelle®
9a	3000.220	3000.220	3000.220	3000.220	Lochschiene	Mounting bar	Barre de montage
9b	3000.240	3000.240	3000.240	3000.240	Klemmhalter	Clamp holder	Attache de support
9c	3000.230	3000.230	3000.230	3000.230	Schiebeteil für Halter	Sliding unit	Pièce coulissante
9d	3000.243	3000.243	3000.243	3000.243	Schraubenset	Screw set	Set vis
9e	3060.400	3060.400	3060.400	3060.400	Halter	Bracket	Support
9f	3000.244	3000.244	3000.244	3000.244	Halter-Erweiterung	Holding device extension	Prolongateur de support

Die Teileabbildung zeigt die mitgelieferten Einzelteile. Die Ersatzteilliste enthält auch Teile die davon abweichen können.
The illustration shows the individual parts supplied. The list of spare parts may also contain parts which deviate.
L'illustration indique les pièces individuelles utilisées. La liste de pièces détachées comporte des pièces pouvant différer de cette illustration.

3000.600

	3000.600	Antriebseinheit	Drive unit	Equipage mobile
1	3000.620	Lagerbuchse	Bearing bush	Coussinet
2	3000.650	Lagerschale	Bearing shell	Coquille
3	3000.640	Antriebswelle	Drive shaft	Arbre d'entraînement
4	3000.660	2 Bremsbacken	2 Brake shoes	2 Mâchoires
5	3000.630	Magnetrotor	Magnetic rotor	Magnetorotor
6	3000.610	Lager oben	Upper bearing	Palier supérieur
7	3000.612	O-Ring, 13x2,5mm	O-ring seal, 13x2,5mm	Joint torique, 13x2,5mm

800/2 1200/2 5001

800/2 - 1200/2 - 5001

	0800/2	1200/2	5001.000	Ersatzteilliste Turbelle® powerhead/electronic	List of spare parts for Turbelle® powerhead/electronic	Liste des pièces Turbelle® powerhead/ electronic
1	0800.015	1200.015	5001.015	Motorblock	Motor block	Bloc moteur
2	3000.020	3000.020	3000.020	O-Ring, 78x2,5mm	O-ring seal, 78x2,5mm	Joint torique, 78x2,5mm
3	3000.600	3000.600	7200.600	Antriebseinheit	Drive unit	Equipage mobile
4	0233.120	0235.120	3000.120	Kreisel	Impeller	Rotor
5	1201.130	1201.130	3000.130	Kreiselgehäuse	Impeller housing	Carter du rotor
6	0235.140	0235.140		2 Klammern	2 clips	2 Clips de verrouillage
7			4002.770	Strömungswinkel	Flow deflector	Déflecteur de flux
8	1200.150	1200.150		Muffe Außen-ø 25mm	Bushing, outside diam. 25mm	Manchon ø 25mm externe
9	3000.780	3000.780	3000.780	Muffe ø25/28mm	Bushing ø25/28mm	Manchon ø25/28mm
10	0104.790			Schlitzkörper, 7cm	Strainer, 7cm (2.7 in.)	Crépine, 7cm
10a		1001.790	1001.790	Schlitzkörper, 12cm	Strainer, 12 cm	Crépine, 12cm
11	3000.250	3000.250	3000.250	Turbelle®-Halter	Turbelle® holder	Support Turbelle®
11a	3000.220	3000.220	3000.220	Lochschiene	Mounting bar	Barre de montage
11b	3000.240	3000.240	3000.240	Klemmhalter	Clamp holder	Attache de support
11c	3000.230	3000.230	3000.230	Schiebeteil für Halter	Sliding unit	Pièce coulissante
11d	3000.243	3000.243	3000.243	Schraubenset	Screw set	Set vis
11e	3060.400	3060.400	3060.400	Halter	Bracket	Support
11f	3000.244	3000.244	3000.244	Halter-Erweiterung	Holding device extension	Prolongateur de support
12			6101.240	Netzteil 15-24V DC	Power Supply Unit 15-24V DC	Alimentation 15-24V DC

Die Teileabbildung zeigt die mitgelieferten Einzelteile. Die Ersatzteilliste enthält auch Teile die davon abweichen können.
The illustration shows the individual parts supplied. The list of spare parts may also contain parts which deviate.
L'illustration indique les pièces individuelles utilisées. La liste de pièces détachées comporte des pièces pouvant différer de cette illustration.

for all Turbelle® electronic > 2000

7200.600

	7200.600	Antriebseinheit	Drive unit	Equipage mobile
1	3000.620	Lagerbuchse	Bearing bush	Coussinet
2	3000.650	Lagerschale	Bearing shell	Coquille
3	3000.640	Antriebswelle	Drive shaft	Arbre d'entraînement
4	3000.660	2 Bremsbacken	2 Brake shoes	2 Mâchoires
5	7400.610	O-Ring Silikon 6 x 1 mm rot	O-ring seal red	Joint torique rouge
6	3000.630	Magnetrotor	Magnetic rotor	Magnetorotor
7	3000.610	Lager oben	Upper bearing	Palier supérieur
8	3000.612	O-Ring, 13x2,5mm	O-ring seal, 13x2,5mm	Joint torique, 13x2,5mm

3

Wartungsanleitung • Maintenance Instructions • Notice d'entretien

Turbelle® powerhead 600/2, 1000/2, 1600/2, 3000/2, 800/2, 1200/2, 220.04, 230.04, 3115.04

Turbelle® electronic 7200/2, 7300/2, 7400/2, 7100/2, 240.04

Das Zerlegen wird anhand einer Turbelle® 3000/2 gezeigt. Da alle powerhead den gleichen Aufbau besitzen gilt sie für alle Turbellen

Zerlegen der Pumpe (siehe Bild 1 - 3)

Bild 1 Gehäuseklammern (1), falls vorhanden, mit kräftigem Daumendruck nach außen von Motor- und Kreiselgehäuserand abdrücken.

Bild 2 Kreiselgehäuse (1) im Uhrzeigersinn bis Haltenase (3) drehen, dann vom Motorblock (2) nach unten abnehmen.

Bild 3 Antriebseinheit (1) mit Kreisel (2) im Uhrzeigersinn drehend herausziehen.

Vorsicht Bruchgefahr! Keramik-Magnetrotor ist stoß- und bruchempfindlich und zieht durch seine Magnetwirkung nach innen = Schnapp-Effekt. Deshalb behutsam herausnehmen.

Zerlegen der Antriebseinheit (siehe Bild 4 -7)

Bild 4 Verriegelungsfeder (1) der Antriebswelle (2) zusammendrücken und gleichzeitig Kreisel (3) anheben und entnehmen. Im Normalfall genügt ein mehrmaliges Durchspülen unter dem Wasserhahn.

Nur im Reparaturfall (sichtbare Verschleißschäden) auseinander nehmen!

Bild 5 Im Reparaturfall Antriebseinheit zerlegen, dazu Magnetrotor (1) festhalten und Antriebswelle (2) gegen Uhrzeigersinn drehen über den Widerstand des Rastpunktes, dabei schieben sich die Bremsbacken (4) seitlich aus dem Gehäuse und können so von Hand herausgezogen werden. Lagerring (3) bei Bedarf mit dem Fingernagel vom Gehäuse der Antriebswelle (2) abziehen.

Bild 6 Inneres Rotorlager (1) im Reparaturfall am besten mit einer Holzschraube 4,5x60mm (2) oder einem Drahtaken herausziehen.

Bild 7 Lagerbuchse (3) im Reparaturfall mit Schraubendreherklinge aushebeln.

Kontrollieren Sie alle Teile auf evtl. Verschleißerscheinungen. Der Austausch eines Teiles für ein paar Mark, kann einen größeren Schaden an Ihrer Turbelle® verhindern. Der Zusammenbau erfolgt, soweit nicht anders vermerkt sinngemäß in umgekehrter Reihenfolge.

The disassembly will be demonstrated by means of a Turbelle® 3000.

As all Turbelle® powerhead units have the same construction, these maintenance instructions shall be applicable for all Turbelle®

Dismantling the pump (cf. Figs 1 – 3)

Fig. 1 Press the housing clamps, if fitted, away from motor and housing edge with strong pressure of your thumbs.

Fig. 2 Turn impeller housing clockwise to retaining nose (3), then remove motor block (2) downwards.

Fig. 3 Draw out drive unit (1) with impeller (2) clockwise.

Caution: Danger of breakage ! Ceramic magnetic rotor is sensitive to blows and breakage and through its magnet effect pulls inwards = snap effect. Therefore, remove carefully.

Dismantling the drive unit (cf. Figs. 4 – 7)

Fig. 4 Press together locking spring (1) of the drive shaft (2) and lift the impeller (3) at the same time. Normally rinsing a few times under the tap is sufficient.

Dismantle only in the case of repair (visible signs of wear).

Fig. 5 In the case of repair dismantle drive unit: to this end hold magnetic rotor (1) tight and turn drive shaft (2) anticlockwise through the resistance of the latching point, at the same time the brake shoes (4) slide out of the side of the housing and may be removed by hand. As and when necessary draw off bearing ring (3) from the housing of the drive shaft (2) with your finger nail.

Fig. 6 Using a wood screw 4.5 x 60 mm (2) or a wire hook, draw out inner rotor bearing (1) in the case of a repair.

Fig. 7 Lift out bearing bush (3) with screwdriver blade in case of repair.

Check all parts for any wear. The replacement of an inexpensive part may prevent a larger damage on your Turbelle®. If nothing to the contrary has been indicated, the assembly is carried out in reverse sequence.

Cette opération de démontage est simulée avec une Turbelle 3000. Etant donné que la conception de toutes les pompes Turbelle Powerhead est similaire, ces indications comptent pour toutes les Turbelle®

Démontage de la pompe (voir vues 1 à 3)

Vue 1 S'ils sont utilisés, détachez les clips de verrouillage (1) par une forte pression des doigts sur les ergots et vers l'extérieur de la chambre de turbine.

Vue 2 Tournez la chambre de turbine (1) dans le sens horaire jusqu'à l'ergot de maintien (3) puis séparez-la du bloc-moteur (2).

Vue 3 Extrayez l'ensemble mobile (1) et sa turbine (2) en effectuant une légère rotation dans le sens horaire.

Attention, risques de bris ! Le magnéto-rotor en céramique est sensible aux chocs. Sa puissance magnétique développe une forte attraction vers le bloc-moteur et implique une extraction avec précaution.

Démontage de la partie mobile (voir vues 4 à 7)

Vue 4 En règle générale, un rinçage minutieux à l'eau courante est suffisant. Ne séparez les pièces qu'en cas de nécessité absolue de réparation (traces d'usure nettement visibles) !

Si nécessaire, appuyez la lame de verrouillage (1) située sur l'arbre d'entraînement (2) tout en saisissant et en détachant la turbine (3).

Vue 5 Si nécessaire, le démontez la partie mobile. Pour cela, maintenez le magnéto-rotor (1) et tournez l'arbre d'entraînement (2) dans le sens anti-horaire au-delà de son point de résistance : les mâchoires de freinage (4) se présentent hors de leur logement et peuvent en être extraites. Si nécessaire, détachez le palier (3) du logement de l'arbre d'entraînement (2) à l'aide de l'ongle.

Vue 6 Si nécessaire, extrayez le palier de rotor intérieur (1) par une rotation à l'aide d'une vis à bois de 4,5 X 60 mm (2) ou à l'aide d'une vrille.

Vue 7 Si nécessaire, démontez le palier principal (3) à l'aide d'un petit tournevis.

Contrôlez attentivement chaque pièce, son degré d'usure et d'encrassement. Pour une somme modique, l'échange éventuel d'une pièce peut éviter la destruction de votre Turbelle®. Le remontage de la pompe obéit tout simplement à l'ordre inverse au démontage.

Zerlegen der Pumpe • Dismantling the pump • Démontage de la pompe

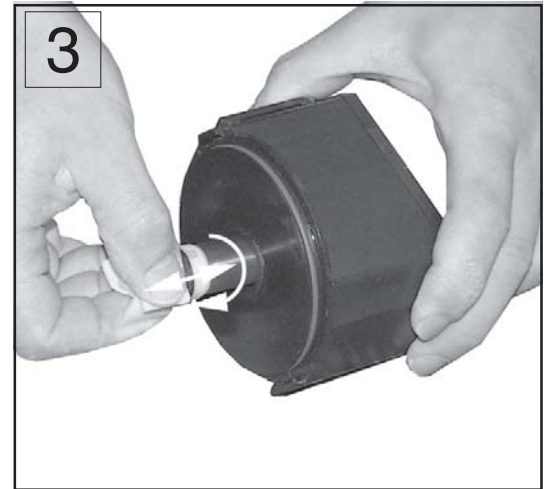
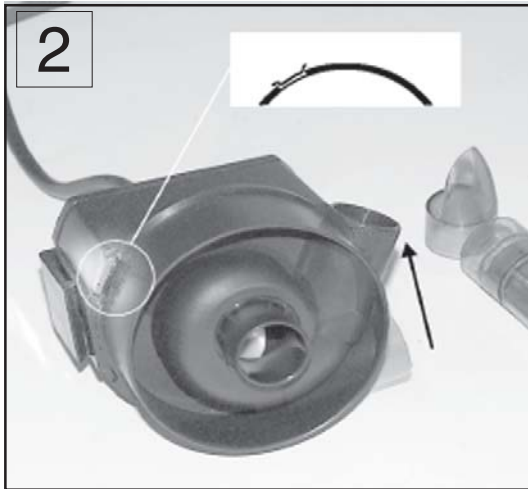

Zerlegen der Antriebseinheit • Dismantling the drive unit • Démontage de la partie mobile

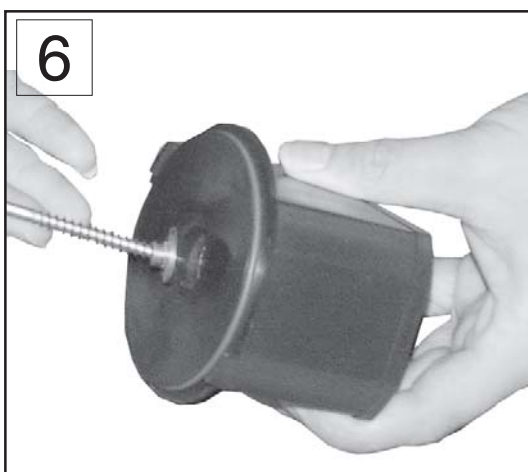
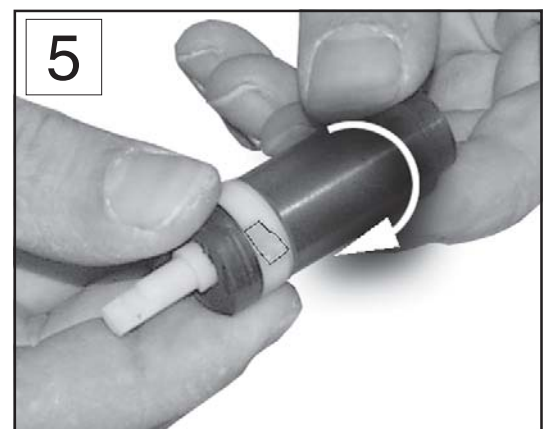
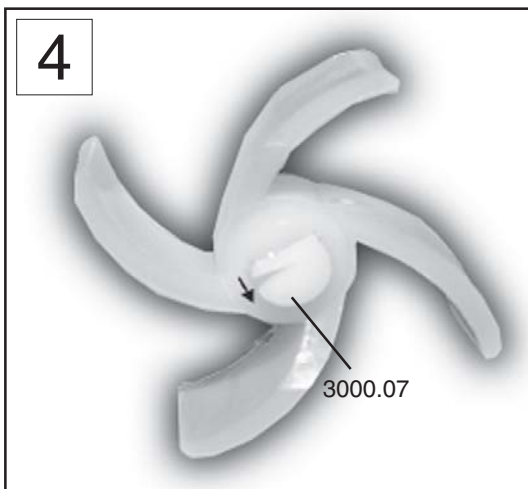

Turbelle® powerhead / electronic < 07/2000

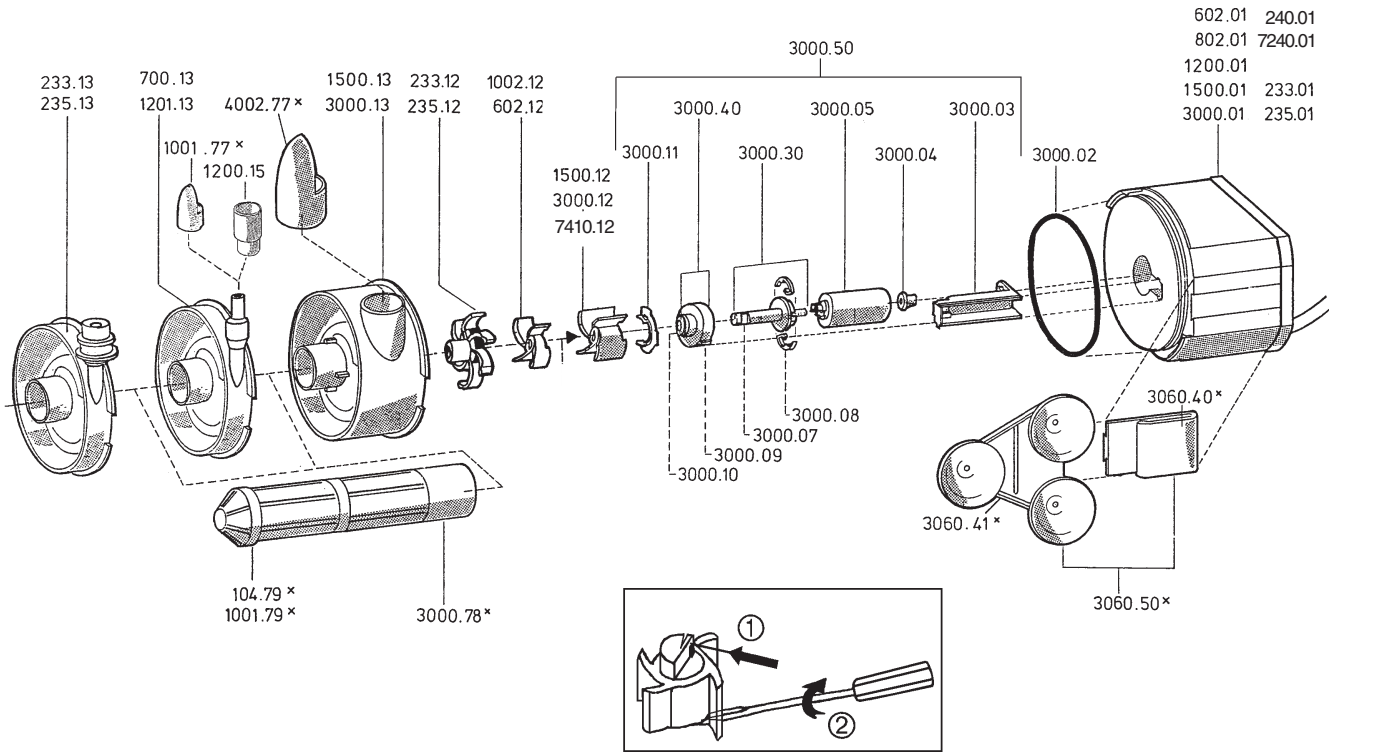

Turbelle® powerhead

Turbelle® powerhead													Teiliste	Partlist	Liste de pièce de rec	
602	603	1002	1003	1500	1501	3000	3001	1200	1201	235.02	802	803	233.02	Turbelle® powerhead	Turbelle® powerhead	Turbelle® powerhead
602.01	602.01	1002.01	1002.01	1500.01	1500.01	3000.01	3000.01	1200.01	1200.01	235.01	802.01	802.01	233.01	Motorblock 230V-50Hz	Engine block 230V-50Hz	Bloc moteur 230V- 50Hz
3000.02	3000.02	3000.02	3000.02	3000.02	3000.02	3000.02	3000.02	3000.02	3000.02	3000.02	3000.02	3000.02	3000.02	O-Ring	O-ring	baque torique
3000.03	3000.03	3000.03	3000.03	3000.03	3000.03	3000.03	3000.03	3000.03	3000.03	3000.03	3000.03	3000.03	3000.03	Kühlkanal	Cooling duct	canal de refroidissement
3000.04	3000.04	3000.04	3000.04	3000.04	3000.04	3000.04	3000.04	3000.04	3000.04	3000.04	3000.04	3000.04	3000.04	Lager oben	Upper bearing	Palier Supérieur
3000.05	3000.05	3000.05	3000.05	3000.05	3000.05	3000.05	3000.05	3000.05	3000.05	3000.05	3000.05	3000.05	3000.05	Magnetrotor	Magnetic rotor	Induit magnétique
3000.07	3000.07	3000.07	3000.07	3000.07	3000.07	3000.07	3000.07	3000.07	3000.07	3000.07	3000.07	3000.07	3000.07	Antriebswelle	Drive shaft	Arbre/entraînement
3000.08	3000.08	3000.08	3000.08	3000.08	3000.08	3000.08	3000.08	3000.08	3000.08	3000.08	3000.08	3000.08	3000.08	Bremsbacken 2 Stück	Breakshoes 2 pcs.	Mâchoires 2 pièce.
3000.30	3000.30	3000.30	3000.30	3000.30	3000.30	3000.30	3000.30	3000.30	3000.30	3000.30	3000.30	3000.30	3000.30	SET (3000.07 + 3000.08)	SET (3000.07 + 3000.08)	SET (3000.07 + 3000.08)
3000.09	3000.09	3000.09	3000.09	3000.09	3000.09	3000.09	3000.09	3000.09	3000.09	3000.09	3000.09	3000.09	3000.09	Lagerschale mit Bremsring	Breakshell with break ring	Coquille de coussinet de frein.
3000.092	3000.092	3000.092	3000.092	3000.092	3000.092	3000.092	3000.092	3000.092	3000.092	3000.092	3000.092	3000.092	3000.092	Bremsring	Break ring	Anneau au freiner
3000.10	3000.10	3000.10	3000.10	3000.10	3000.10	3000.10	3000.10	3000.10	3000.10	3000.10	3000.10	3000.10	3000.10	Lagerbuchse V4A	Bearingbush V4A	Coussinet V4A
3000.40	3000.40	3000.40	3000.40	3000.40	3000.40	3000.40	3000.40	3000.40	3000.40	3000.40	3000.40	3000.40	3000.40	SET (3000.09 + 3000.10)	SET (3000.09 + 3000.10)	SET (3000.09 + 3000.10)
3000.11	3000.11	3000.11	3000.11	3000.11	3000.11	3000.11	3000.11	3000.11	3000.11	3000.11	3000.11	3000.11	3000.11	Klemmring	Clamping ring	Bague de serrage
602.12	602.12	1002.12	1002.12	1500.12	1500.12	3000.12	3000.12	235.12	235.12	235.12	233.12	233.12	233.12	Kreisell	Impeller	Rotor
700.13	700.13	1500.13	1500.13	1500.13	1500.13	3000.13	3000.13	1201.13	1201.03	235.13	1201.13	1201.03	233.13	Kreiselgehäuse	Impeller housing	Carter du rotor
		1002.15	1002.15											Adapter	Adaptor	Ajutage
		3000.78		3000.78		3000.78								Rohrmuffe	Connecting sleeve	Manchon de tuyau
								1200.15	1200.15		1200.15	1200.15		Muffe für Schlauchanschluß	Sleeve for hose connection	Manchon pour raccord tuyau
104.79		104.79		1001.79		1001.79					104.79			Schlitzkörper	Strainer	Tube fendu
3060.40	3060.40	3060.40	3060.40	3060.40	3060.40	3060.40	3060.40	3060.40	3060.40	3060.40	3060.40	3060.40	3060.40	Halter	Holder	Fixation
3060.41	3060.41	3060.41	3060.41	3060.41	3060.41	3060.41	3060.41	3060.41	3060.41	3060.41	3060.41	3060.41	3060.41	Saughalter mit 3060.42	Suction holder with 3060.42	Support a vent. avec 3060.42
3060.42	3060.42	3060.42	3060.42	3060.42	3060.42	3060.42	3060.42	3060.42	3060.42	3060.42	3060.42	3060.42	3060.42	Sauger 3 Stück	Suction 3 pcs.	Support 3 pièce.
3060.50	3060.50	3060.50	3060.50	3060.50	3060.50	3060.50	3060.50	3060.50	3060.50	3060.50	3060.50	3060.50	3060.50	SET (3060.40 + 3060.41)	SET (3060.40 + 3060.41)	SET (3060.40 + 3060.41)
3000.14	3000.14	3000.14	3000.14	3000.14	3000.14	3000.14	3000.14	3000.14	3000.14	3000.14	3000.14	3000.14	3000.14	Rahmenhalterung	Frame holding device	Fixation du cadre
1001.77	4002.77		4002.77		4002.77		4002.77							Störmungswinkel	Flow deflector	Cône d'écoulement

Turbelle® electronic

7240	7241	7180	7181	240.02	Turbelle® electronic Pumpe	Turbelle® electronic pump	Turbelle® electronic pompe
7240.01	7240.01	7180.01	7180.01	240.01	Motorblock 24V	Motor block 24V	Bloc moteur 24V
3000.02	3000.02	3000.02	3000.02	3000.02	O-Ring	O-ring seal	Bague torique
3000.03	3000.03	3000.03	3000.03	3000.03	Kühlkanal	Cooling duct	Canal de refroidissement
3000.04	3000.04	3000.04	3000.04	3000.04	Lager oben	Upper bearing	Palier supérieur
3000.05	3000.05	3000.05	3000.05	3000.05	Magnetrotor	Magnetic rotor	Induit magnétique
3000.07	3000.07	3000.07	3000.07	3000.07	Antriebswelle	Drive shaft	Arbre d'entraînement
3000.08	3000.08	3000.08	3000.08	3000.08	Bremsbacken 2 Stück	Brake shoes (2 items)	Mâchoires (2 pièces)
3000.30	3000.30	3000.30	3000.30	3000.30	SET (3000.07 + 3000.08)	SET (3000.07 + 3000.08)	SET (3000.07 + 3000.08)
3000.09	3000.09	3000.09	3000.09	3000.09	Lagerschale mit Bremsring	Bearing shell with brake ring	Coquille de coussinet a. baague de r.
3000.092	3000.092	3000.092	3000.092	3000.092	Bremsring	Brake ring	Anneau au freiner
3000.10	3000.10	3000.10	3000.10	3000.10	Lagerbuchse V4A	Bearing bush V4A	Coussinet V4A
3000.40	3000.40	3000.40	3000.40	3000.40	SET (3000.09 + 3000.10)	SET (3000.09 + 3000.10)	SET (3000.09 + 3000.10)
3000.11	3000.11	3000.11	3000.11	3000.11	Klemmring	Clamping ring	Bague de serrage
7410.12	7410.12	3000.12	3000.12	3000.12	Kreisell	Impeller	Rotor
		7410.12	7410.12		Kreisell	Impeller	Rotor
3000.13	3000.13	1201.13	1201.13	235.13	Kreisellgehäuse	Impeller housing	Carter du rotor
		3000.13	3000.13		Kreisellgehäuse	Impeller housing	Carter du rotor
		1200.15	1200.15		Muffe ø 25mm für 1201.13	Sleeve ø25mm 1201.13	Manchon ø25mm pour 1201.13
		1282.15	1282.15		Muffe ø 25mm für 1282.13	Sleeve ø25mm 1282.13	Manchon ø25mm pour 1282.13
3000.78		3000.78			Muffe	Sleeve	Manchon
1001.79		1001.79			Schlitzkörper	Strainer	Tube fendu
3060.40		3060.40			Halter	Holding device	Fixation
3060.41		3060.41			Saughalter	Suction cup unit	Support à ventouses
3060.42		3060.42			Sauger 3 Stück	Suction cup (3 pcs.)	Ventouses (3 pièces)
3060.50		3060.50			SET (3060.40 + 3060.41)	SET (3060.40 + 3060.41)	SET (3060.40 + 3060.41)
3000.14		3000.14			Rahmenhalterung	Frame holding device	Fixation du cadre
4002.77					Störmungswinkel	Flow deflector	Cône d'écoulement

Wartungsanleitung • Maintenance Instructions • Notice d'entretien

Turbelle® powerhead 602/603, 1002/1003, 1500/1501, 3000/3001, 802/803, 1200/1201, 233.02, 235.02
Turbelle® electronic 7210P/7211P, 7310P/7311P, 7410P/7411P, 7110U/7111U, 240.02



Das Zerlegen wird anhand einer Turbelle® 3000 gezeigt. Da alle powerhead den gleichen Aufbau besitzen gilt sie für alle Turbelle®

The disassembly will be demonstrated by means of a Turbelle® 3000. As all Turbelle® powerhead units have the same construction, these maintenance instructions shall be applicable for all Turbelle®

Cette opération de démontage est simulée avec une Turbelle 3000. Etant donné que la conception de toutes les pompes Turbelle Powerhead est similaire, ces indications comptent pour toutes les Turbelle®

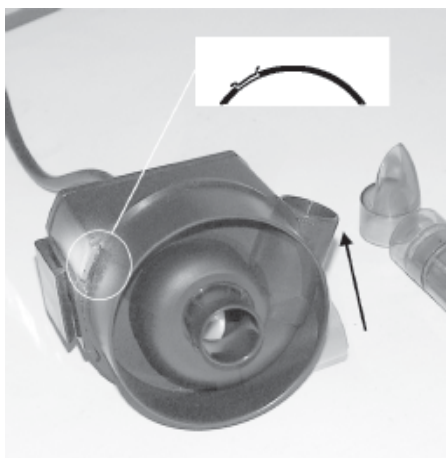

Drehen Sie das Kreiselgehäuse soweit gegen den Uhrzeigersinn, bis es sich nach unten abziehen läßt.

Turn the impeller housing clockwise until it can be pulled off to the bottom.

Tournez la chambre de turbine en sens anti-horaire jusqu'à son détachement de la pompe.

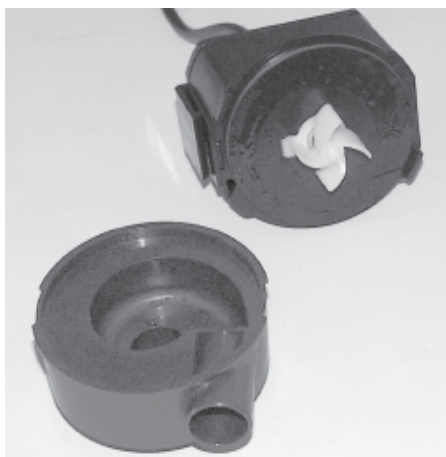

Nehmen Sie das Kreiselgehäuse vom Pumpenkopf ab.

Remove the impeller housing from the pump head.

Déposez la chambre de turbine.

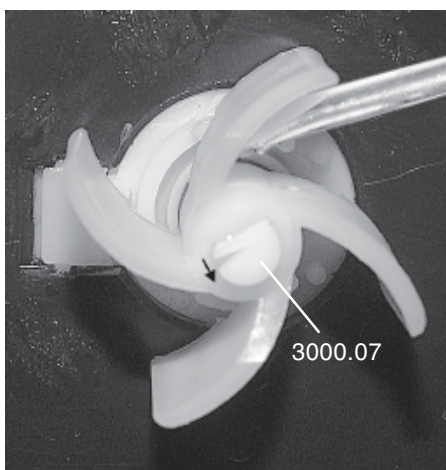

Drücken Sie die Verriegelungsfeder der Antriebswelle (3000.07) zusammen, und hebeln Sie den Kreisel ab (Schraubenzieher).

Press the locking spring of the drive shaft (3000.07) together and lift the impeller off (screw-driver).

Appuyez sur la lame de ressort se situant sur l'arbre d'entraînement (3000.07) et détachez la turbine en faisant levier avec un petit tournevis.

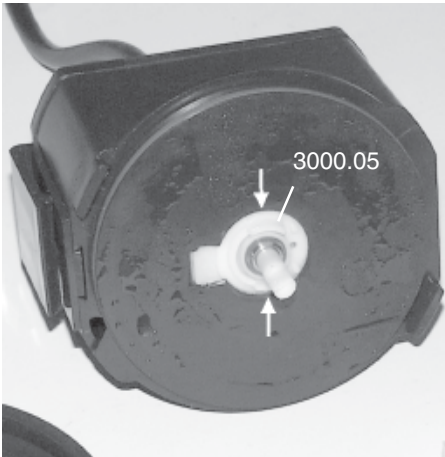

Drücken Sie den Klemmring (3000.11) zusammen, und entnehmen Sie ihn aus seiner Führung.

Press the clamping ring (3000.11) together and remove it from its guideway.

Pincez la bague de serrage (3000.11) de manière à pouvoir l'extraire de son logement.

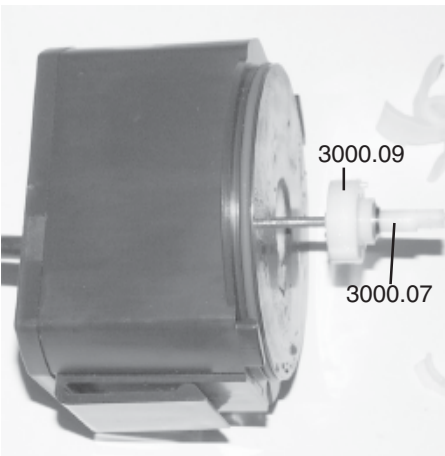

Ziehen sie die Antriebswelle (3000.07) und Lagerschale (3000.09) aus dem Pumpenkopf. Achten Sie beim Wiedereinsetzen auf die richtige Position der Rastnut.

Pull the drive shaft (3000.07) and the bearing shell (3000.09) out of the pump head. In assembly, please observe the right position of the snap-in groove.

Tirez l'arbre d'entraînement (3000.07) de manière à sortir l'arbre et l'ensemble coquille de freinage (3000.09) de la pompe. Lors de la mise en place, veuillez à bien positionner le téton détromper.

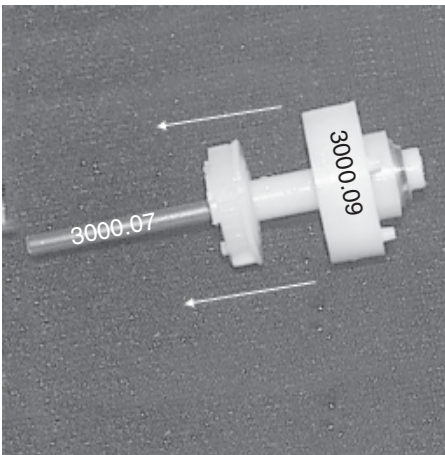

Ziehen Sie die Antriebswelle (3000.07) aus der Lagerschale (3000.09).

Pull the drive shaft (3000.07) out of the bearing shell (3000.09).

Séparez l'arbre d'entraînement (3000.07) de la coquille de freinage (3000.09).

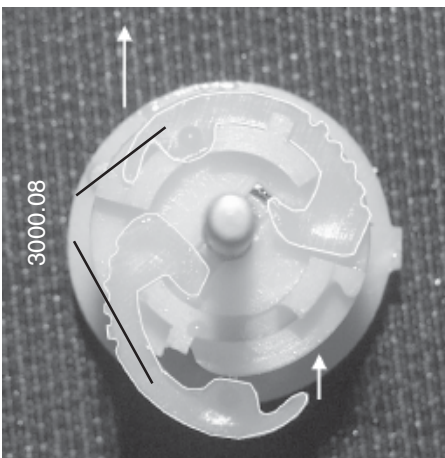

Bremsbacken (3000.08) an der schmalen Seite nach außen ziehen und entnehmen (oben). Zum Einsetzen die Bremsbacken mit der breiten Seite einhängen, und die schmale nach innen einrasten (unten).

Pull the brake shoe (3000.08) to the outside at the narrow part, and remove it (upwards). For assembly, attach the brake shoe on the broad side and permit the narrow part to snap in (bottom).

En les saisissant sur leurs parties les plus fines, sortez les mâchoires de freins (3000.08) (en haut). Pour la remise en place des mâchoires, enclipez tout d'abord la partie large puis introduisez la partie la plus fine (en bas).



Den Bremsring (3000.092) nur wenn Schäden erkennbar sind, aus der Lagerschale (3000.09) herausziehen.

Pull the brake ring (3000.092) out of the bearing shell (3000.09) only, if damage is visible.

Seulement s'il possible de constater une détérioration, sortez la garniture de freinage (3000.092) de la coquille de freinage (3000.09).



Hebeln Sie den Kühlkanal (3000.03) aus dem Pumpenkopf. Ziehen Sie den Magnetrotor mittels des Kühlkanales vollständig aus seiner Führung.

Prize off the cooling duct (3000.03) from the pump head. Use the cooling duct to pull the magnetic rotor out of the guideway completely.

A l'aide d'un tournevis, extrayez le canal de refroidissement (3000.03) de la pompe. Saisissez le rotor poussé par la translation du canal.

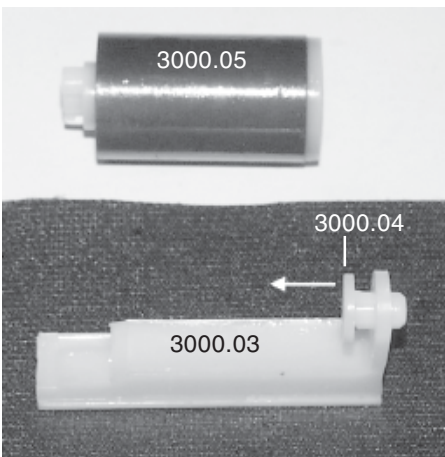

Nehmen Sie den Magnetrotor (3000.05) vom Kühlkanal (3000.03) und ziehen Sie das obere Lager (3000.04) aus der Führung.

Remove the magnetic rotor (3000.05) from the cooling duct (3000.03), and pull the upper bearing (3000.04) from the guideway.

Déposez le rotor (3000.05) de son canal de refroidissement (3000.03) et sortez le palier supérieur (3000.04) de son logement.



Kontrollieren Sie alle Teile auf evtl. Verschleißerscheinungen. Der Austausch eines Teiles für ein paar Mark, kann einen größeren Schaden an Ihrer Turbelle® verhindern. Der Zusammenbau erfolgt, soweit nicht anders vermerkt sinngemäß in umgekehrter Reihenfolge.

Check all parts for any wear. The replacement of an inexpensive part may prevent a larger damage on your Turbelle®. If nothing to the contrary has been indicated, the assembly is carried out in reverse sequence.

Contrôlez attentivement chaque pièce, son degré d'usure et d'encrassement. Pour une somme modique, l'échange éventuel d'une pièce peut éviter la destruction de votre Turbelle®. Le remontage de la pompe obéit tout simplement à l'ordre inverse au démontage.

Turbelle®

stream old model

Teileabbildung • Illustration of parts • Illustration des pièces

Teileabbildung • Illustration of parts • Illustration des pièces

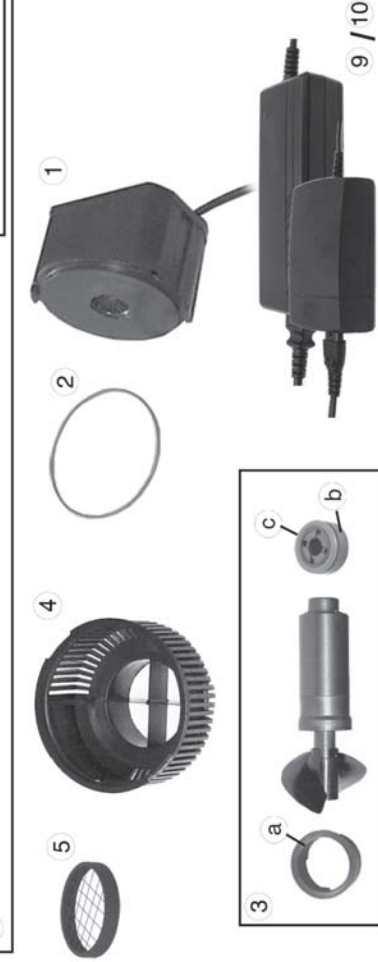
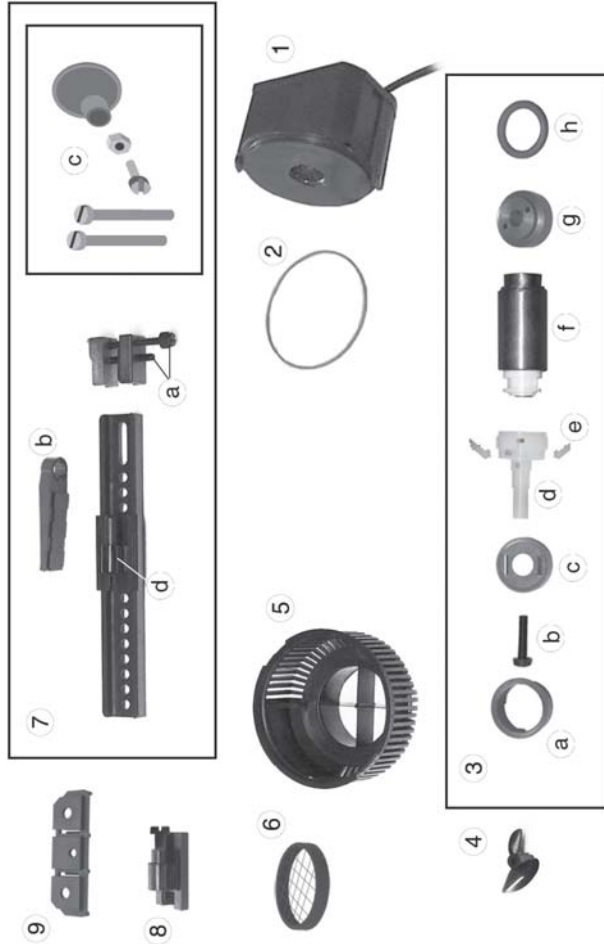

6060.000	6080.000	6130.000	Ersatzteilliste Turbelle® stream	List of spare parts Turbelle® stream	Liste des pièces Turbelle® stream
1	6060.015	6080.015	6130.015	Motor block	Bloc moteur
2	3000.020	3000.020	3000.020	O-ring seal, 78x2.5mm	Joint torique, 78x2,5mm
3	6080.600	6080.600	6080.600	Drive unit	Entraînement
3a	3000.620	3000.620	3000.620	Bearing bush	Coussinet
3b	6080.641	6080.641	6080.641	Screw M4x16	Vis M4x16
3c	3000.650	3000.650	3000.650	Lagerschale	Coquille
3d	6080.640	6080.640	6080.640	Arbre d'entraînement	Arbre d'entraînement
3e	3000.660	3000.660	3000.660	2 Brake shoes	2 Mâchoires
3f	3000.630	3000.630	3000.630	Magnetrotor	Magnetrotor
3g	3000.610	3000.610	3000.610	Lager oben	Palier supérieur
3h	3000.612	3000.612	3000.612	O-Ring, 13x2.5mm	Joint torique, 13x2,5mm
4	6060.120	6080.120	6200.120	Hydropropeller	Hydropropulseur
5	6080.130	6080.130	6200.130	Ansauggehäuse	Corps d'aspiration
6	6080.200	6080.200	6212.200	Schutzgitter	Grille de protection
7	6080.250	6080.250	6080.250	Turbelle®-Halter	Support Turbelle®
7a	3000.243	3000.243	3000.243	Schraubenset	Set vis
7b	6080.400	6080.400	6080.400	Schwenkarm	Bras pivotant
7c	3000.244	3000.244	3000.244	Halter-Erweiterung	Prolongateur de support
7d	6080.230	6080.230	6080.230	Schiebeteil mit Angel	Pièce couliss. avec gond
8		6200.230		Schiebeteil + Schraube	Pièce couliss. avec vis
9		6080.250		Halter-Stabilisator	Stabilisateur support

Die Teileabbildung zeigt die mitgelieferten Einzelteile. Die Ersatzteilliste enthält auch Teile die davon abweichen können. The illustration shows the individual parts supplied. The list of spare parts may also contain parts which deviate. L'illustration indique les pièces individuelles utilisées. La liste de pièces détachées comporte des pièces pouvant différer de cette illustration.

6101.000	6201.000	6301.000	Ersatzteilliste Turbelle® stream	List of spare parts Turbelle® stream	Liste des pièces Turbelle® stream
1	6101.015	6201.015	6301.015	Motorblock	Bloc moteur
2	3000.020	3000.020	3000.020	O-Ring, 78x2.5mm	Joint torique, 78x2,5mm
3	6100.700	6200.700	6300.700	Antriebsseinheit+Propeller	Entraînement + propulseur
3a	3000.620	3000.620	3000.620	Lagerbuchse	Coussinet
3b	3000.610	3000.610	3000.610	Lager oben	Palier supérieur
3c	3000.612	3000.612	3000.612	O-Ring, 13x2.5mm	Joint torique, 13x2,5mm
4	6080.130	6200.130	6300.130	Ansauggehäuse ø63mm	Corps d'aspiration ø63mm
5	6080.200	6212.200	6212.200	Schutzgitter	Grille de protection
6	6200.255	6200.255		Turbelle®-Halter	Support Turbelle®
6a	3000.243	3000.243		Schraubenset	Set vis
6b	6080.400	6080.400		Schwenkarm	Bras pivotant
6c	3000.244	3000.244		Halter-Erweiterung	Prolongateur de support
6d	6200.230	6200.230		Schiebeteil + Schraube	Pièce couliss. avec vis
6e	6080.250	6080.250		Halter-Stabilisator	Stabilisateur support
6f	3000.220	3000.220		Lochschiene	Barre de montage
7			1281.313	2 Schrauben+2Muttern M6	2 vis+ 2 écrous M6x16mm
8			6080.230	Schiebeteil mit Angel	Pièce couliss. avec gond
9	6101.240			Netzteil 15-24V DC	Alimentation 15-24V DC
10		6300.240		Netzteil 24V DC	Alimentation 24V DC

Die Teileabbildung zeigt die mitgelieferten Einzelteile. Die Ersatzteilliste enthält auch Teile die davon abweichen können. The illustration shows the individual parts supplied. The list of spare parts may also contain parts which deviate. L'illustration indique les pièces individuelles utilisées. La liste de pièces détachées comporte des pièces pouvant différer de cette illustration.

Wavebox 6212

Teileabbildung der Wavebox • Illustration of parts of the Wavebox
Illustration des pièces Wavebox



Ersatzteilliste • List of spares • Liste de pièces

	Wavebox	Wavebox	Wavebox
6212.000	Wavebox	Wavebox	Wavebox
1	6212.100 Wavebox-Gehäuse	Corps de Wavebox	Corps de Wavebox
2	6261.000 Wavebox-Pumpe	Wavebox pump	Pompe-Wavebox
3	6250.510 O-Ring Silikon 50 x 6 mm	O-ring seal 50x6 mm	Joint torique 50x6 mm
4	6212.200 Schutzgitter	Protective grating	Grille de protection
5	Sponge-ring	Mousse de maintien	
6	6212.020 Deckel mit 12 Schlitzen	Cover with twelve slots.	Couvercle à 12 ouvertures
7	6212.070 Sicherungsplatte	Retaining plate	Plaque de verouillage
8	3166.250 Comline-Halter	Comline support	Support Comline
8a	3000.240 Klemmhalter	Clamp holder	Attache de support
8b	1281.313 2 Schrauben+2Muttern M6	2 screw+2 nuts M6x16mm	2 vis+ 2 écrous M6x16mm
8c	3000.244 Halter-Erweiterung	Holding device extension	Prolongateur de support
8d	3060.420 Sauger 3 Stück	Sauger 3 pcs.	Ventouses 3 pièces
9	6091.000 Wavecontroller	Wavecontroller	Wavecontroller
10	7094.050 Fotozelle	Photo-electric cell	Cellule photo
11	6101.240 Netzteil 15-24V DC	Power Supply Unit 15-24 VDC	Alimentation 15-24V DC

Teileabbildung der Wavebox-Pumpe • Illustration of parts of the Wavebox pump
Illustration des pièces pompe-Wavebox

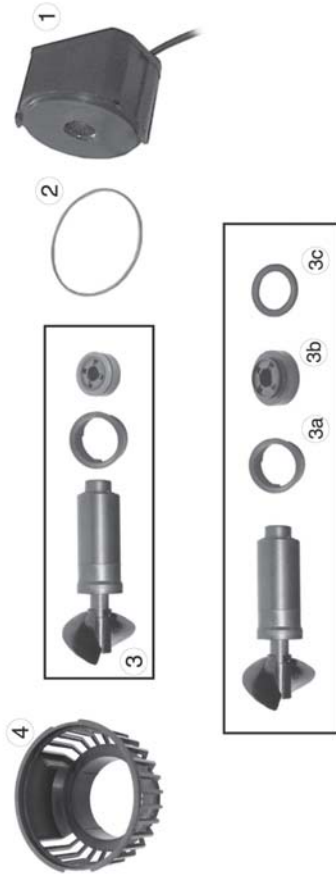

Ersatzteilliste • List of spares • Liste de pièces

	Wavebox-Pumpe	Wavebox pump	Pompe-Wavebox
6261.000	Motorblock	Motor block	Bloc moteur
1	6261.015 O-Ring, 78x2,5mm	O-ring seal, 78x2,5mm	Joint torique, 78x2,5mm
2	3000.020 Antriebseinheit+Propeller	Drive unit + propeller	Entrainement + pulseur
3	3000.620 Lagerbuchse	Bearing bush	Coussinet
3a	3000.610 Lager oben	Upper bearing	Pailier supérieur
3b	3000.612 O-Ring, 13x2,5mm	O-ring seal, 13x2,5mm	Joint torique, 13x2,5mm
3c	6300.130 Ansauggehäuse	Suction housing	Corps d'aspiration
4			

Die Teileabbildung zeigt die mitgelieferten Einzelteile. Die Ersatzteilliste enthält auch Teile die davon abweichen können.

The illustration shows the individual parts supplied. The list of spare parts may also contain parts which deviate.

L'illustration indique les pièces individuelles utilisées. La liste de pièces détachées comporte des pièces pouvant différer de cette illustration.

Turbelle® nanostream®

Teileabbildung • Illustration of parts • Illustration des pièces

			Turbelle® nanostream®			
1	6025.100	6045.100	6055.100	Motorblock	Motor block	Bloc-moteur
2	6025.130	6045.130	6045.130	Propellergehäuse	Propeller housing	Corps de pompe
3	6025.700	6025.700	6025.700	Antriebseinheit	Drive unit	Entraînement
4	6025.740	6025.740	6025.740	Scheibe für Antrieb	Disc for drive	Rondelle d'entraînement
5	6025.510	6025.510	6025.510	Klemme	Clamp	Pince
6	6025.500	6025.500	6025.500	Magnet Holder	Magnet Holder	Magnet Holder
7			6055.240	Netzteil 12-24V DC	Power supply unit 12-24V DC	Alimentation 12-24V DC
8	6025.200	6025.200	6025.200	Schutzgitter	Protective grating	Grille de protection
9	6200.509	6200.509	6200.509	9 Elastikpuffer f. Magnet Holder	9 elastic pads f. Magnet Holder	9 tampons pour Magnet Holder

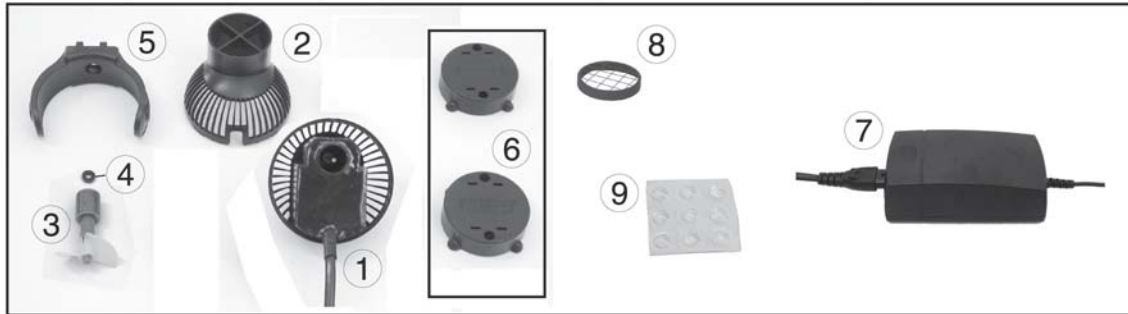

Turbelle® stream



		6060	6080	6000	6100	6200	Turbelle® stream		
1	6060	6080	6100.10	6100.10	6200.10	Pumpe	Pump	Pompe	
2			7240.27	7240.27	7240.27	Treiber	Driver	Driver	
3			7210.202	7410.602	6200.80	Trafo	Transformer	Transformateur	

all other parts see Turbelle® stream new model

	2002	4002	Teilleiste	List of Parts	Liste de pièces
1	104.19	104.19	Schraube V2A M3x10	Screw V2A M3x10	Vis V2A M3x10
2	2002.02	4002.02	Deckel	Lid	Couvercle
3	4002.09	4002.09	Lüfter	Fan	Ventilateur
4	4002.26	4002.26	Motorlager (2St.)	Motor bearing (2pcs.)	Palier moteur (2pièces)
5	2002.11	4002.11	Motor 220V mit Kabel vergossen (mit 5a)	Motor 220V sealed with main cable (with 5a)	Moteur 220V coulé avec câble (avec 5a)
5a	2002.22	4002.22	Motoranker	Rotor	Inclut
6	4002.08	4002.08	Knebel (10St.)	Retainer (10pcs.)	Bouchon (10pièces)
7	4002.12	4002.12	Gummifuß (4St.)	Rubber mount (4pcs.)	Pied caoutchouc (4pièces)
8	4002.07	4002.07	Holm (2St.)	Motor bearer (2pcs.)	Traverse (2pièces)
9	4002.20	4002.20	Wellenrohr (mit 9a / 9b)	Shaft housing (with 9a / 9b)	Collone d'axe (avec 9a / 9b)
9a	4002.203	4002.203	Filzstreifen	Felt strip	Langnette de feutre
9b	4002.202	4002.202	Spannring	Clamping ring	Anneau tendeur
10	4002.06	4002.06	Schraube V2A M4x20	Screw V2A M4x20	Vis V2A M4x20
11	2002.10	4002.10	Motorgehäuse	Motor housing	Boîtier moteur
12	4002.13	4002.13	Welle (mit Ritzel 12a)	Shaft set (with 12a)	Axe complet (avec 12a)
12a	4002.131	4002.131	Ritzel mit Feder	Pinion with spring	Roue avec ressort
13	102.40	102.40	Spannhalter V4A	Mounting clamp V4A	Attache V4A
14	851.44	851.44	Scheibe	Disc	Disque
15	102.43	102.43	Schraube V4A M6x12	Screw V4A M6x12	Vis V4A M6x12
16	141.14	141.14	Lagerscheibe	Thrust washer	Rondelle
17	141.15	141.15	Kreisellager	Impeller bearing	Coussinet du rotor
18	121.16	141.16	Kreiselgehäuse	Impeller housing	Carter du rotor
19	121.17	141.17	Kreisel	Impeller	Rotor
20	141.18	141.18	Schraubstutzen	Intake fitting	Reccord fileté
21	4002.25	4002.25	Reparaturbeutel (1, 12, 16, 17)	Repair kit (1, 12, 16, 17)	Set réparation (1, 12, 16, 17)
			Zubehör (extra bestellen)	Accessories (order separately)	Accessoires (commander séparément)
Z1	102.41	102.41	Spannwinkel V4A	Universal bracket V4A	Cornière V4A
Z2	851.41	851.41	Halter für TUNZE SYSTEM	Holder for TUNZE SYSTEM	Support pour TUNZE SYSTEM
Z3	708	708	powertimer	powertimer	powertimer
Z4	7082	7082	powertimer mit Ebbe-Flut Steuerung	powertimer with high and low tide simulation	powertimer av. créer un mouvement de marée
Z5	4002.77	4002.77	Strömungswinkel	Flow deflector	Coue d'écoulem
Z6	2002.71	2002.71	Bio-Anschluß	Bio connection	Raccord bioZ7
Z7	1001.79	1652.79	Schlitzkörper	Strainer	Crépine
Z8	1001.76	1001.76	Rohrstück	Tube	Partie de tuyau
Z9	1001.78	1001.78	Rohrmuffe ø21/25	Connecting sleeve ø21/25	Manchon de tuyau ø21/25
Z10	3000.78	3000.78	Rohrmuffe ø25/28	Connecting sleeve ø25/28	Manchon de tuyau ø25/28
Z11	1001.80	1001.80	T-Stück	T piece	Branchement en T

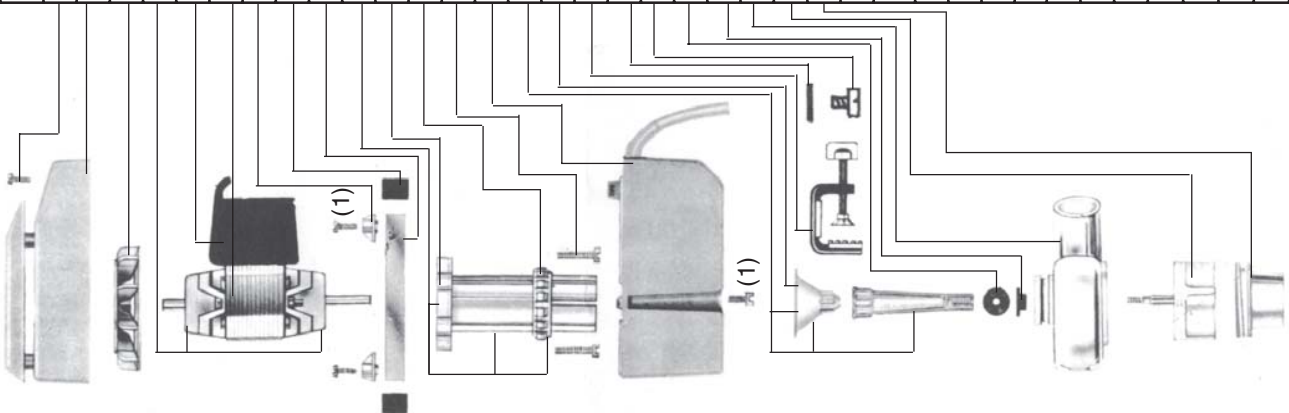

ComLine Filter 3166 / 3167

Teileabbildung • Illustration of parts • Illustration des pièces 3166 / 3167

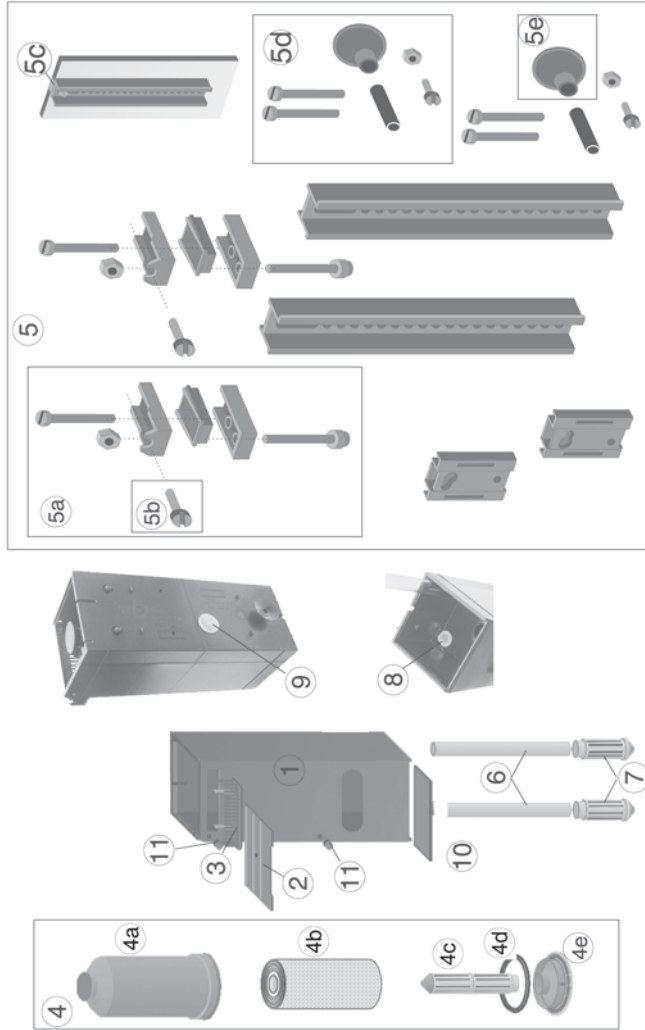

3166	3167	Ersatzteilliste	List of spares	Liste des pièces
1	3167.10	Gehäuse	Housing	Corps de filtre
2	3166.02	Schiebedeckel	Sliding cover	Couvercle
3	5000.15	Ansaugschutz	Protective grid	Grille d'aspiration
4	3166.20	Comline-Glocke kompl.	Comline bell complete	Cloche Comline complète
4a	3166.28	Topf mit Griff	Pot with handle	Cloche avec poignée
4b	800.01	Filterpatronen (5 Stück)	Filter cartridges (5 ea.)	Cartouches filtrantes (5 p.)
4c	800.06	Schlitzkörper	Strainer	Crépine de cloche
4d	820.29	Rücklaufsperr	Return stop	Anti-retour
4e	820.25	Schraubendeckel	Screw cap	Couvercle à visser
5	3166.25	Comline Halter	Comline holder	Support Comline
5a	3000.24	Klemmhalter	Clamp holder	Attache de support
5b	1281.313	2 Schrauben + 2 Muttern M6	2 screw + 2 nuts M6	2 viss + 2 écrou M6
5c	3000.28	Haltebügel	Holding bracket	Etrier pour support
5d	3000.244	Halterweiterung	Holding device extension	Prolongateur de support
5e	3060.44	Sauger (4 Stück)	Suction cup (4 pcs.)	Ventouses (4 pièces)
6	2 x 3166.76	4 x 3166.76	Tube 19 x 300	Tuyau 19 X 300
7	2 x 104.79	4 x 104.79	Schlitzkörper	Crépine
8	3166.05	2 x 3166.05	Kappe H7A, ø 19mm	Obturbateur H7A, ø 19mm
9	235.481	2 x 235.481	Kappe H14, ø 26mm	Obturbateur H14, ø 26mm
10	3166.07	Sicherungsplatte	Retaining plate	Plaque de verrouillage
11	2 x 3166.06	3 x 3166.06	Kappe schwarz ø 9,5 mm	Obturbateur noir ø 9,5mm

ComLine Bio-Hydro-Reactor 3179

Teilliste • List of parts • Liste de pièces 3179

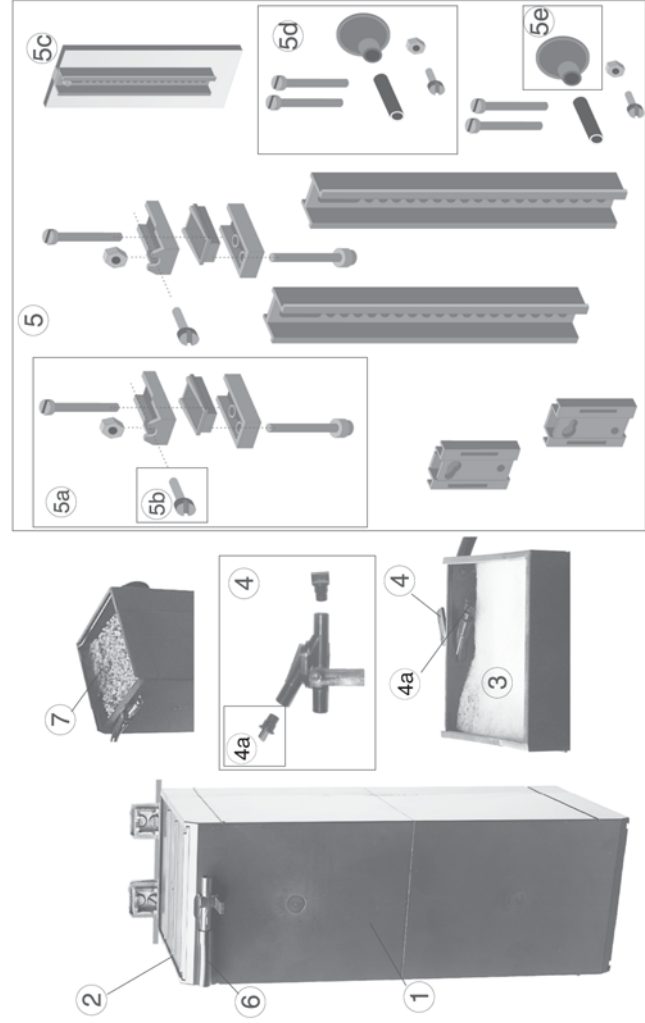

3179	Teilliste	List of parts	Liste de pièces
1	3179.10	Gehäuse	Corps de filtre
2	3166.02	Schiebedeckel	Couvercle
3	3197.05	Filtervlies	Filter mat
4	0390.460	Y-Abzweigung	Y-branch
4a	879.711	Biowasser-Verteilerdüse	Distribution nozzle
5	3166.25	Comline Halter	Comline holder
5a	3000.24	Klemmhalter	Clamp holder
5b	1281.313	2 Schrauben + 2 Muttern M6	2 screw + 2 nuts M6
5c	3000.28	Haltebügel	Holding bracket
5d	3000.244	Halterweiterung	Holding device extension
5e	3060.44	Sauger (4 Stück)	Suction cup (4 pcs.)
6	1678.39	Schlauch 6x9mm	Hose 6x9mm (.23x.35 in.)
7	875.95	Granovit 700ml	Granovit 700ml

ComLine DOC Skimmer

Teileabbildung • Illustration of parts • Illustration des pièces

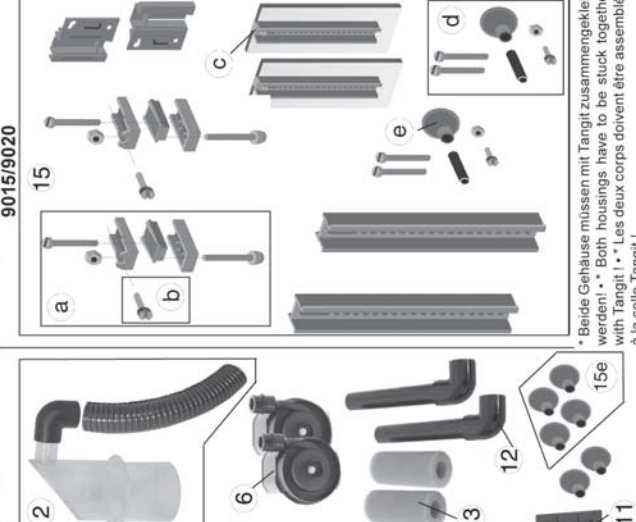
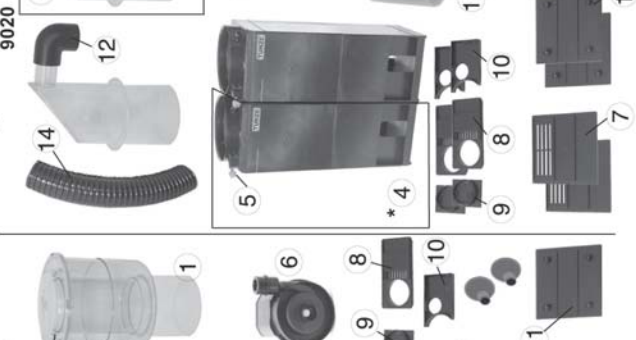
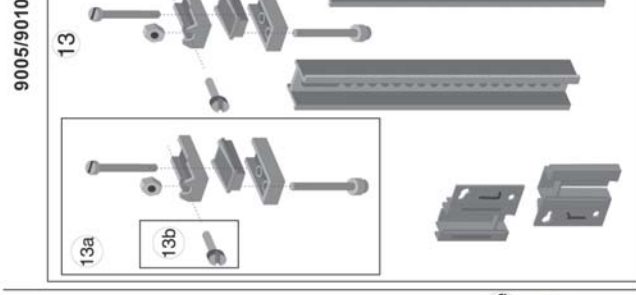
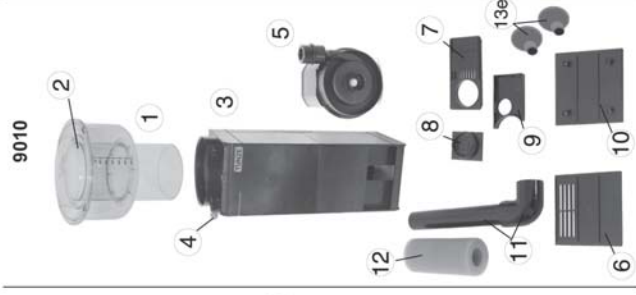

* Beide Gehäuse müssen mit Tangit zusammengeklebt werden! • • Both housings have to be stuck together with Tangit! • • Les deux corps doivent être assemblés à la colle Tangit!

9005	9010	Ersatzteilliste Abschäumer 9005,9010	List of spare parts Skimmer 9005,9010	Liste des pièces Ecumeur 9005, 9010
1	9005.140	Schaumtopf	Skimmer cup	Godet d'écumage
2	0214.150	Schaumtopfdeckel	Skimmer cup lid	Couvercle de godet
3	9010.100	Gehäuse	Housing	Corps d'écumeur
4	9010.360	Luftinstellschraube M8	Air regulator screw M8	Vis de réglage M8
5	9005.040	Hydrofoamer	Hydrofoamer	Hydrofoamer
6	3130.020	Deckel mit 4 Schlitzfen	Cover with four slots	Couvercle à 4 ouvertures
7	9010.300	Abdeckung mit Schiebendeckel	Cover with sliding cover	Couvercle frontal à coulisse
8	9010.350	Kappe auf Abdeckung	Cap with cover	Obtrateur
9	9010.400	Muffe unter Abdeckung	Sleeve below cover	Pièce manchon
10	9010.200	Deckel für Sauger	Cover for aspirator	Couvercle pour ventouses
11	9010.700	Rohr mit Muffe	Tube with bushing	Tuyau et coude
12	0800.140	Patronenkern zu 800.22	Cartridge core to 800.22	Coeur de cartouche p.800.22
13	3130.250	Comline-Schäumer-Halter	Comline skimmer support	Support d'écumeur Comline
13a	3000.240	3000.240 Klemmhalter	Clamp holder	Attache de support
13b	1281.313	2 Schrauben+2Muttern M6	2 screw+2 nuts M6x16mm	2 vis+ 2 écrous M6x16mm
13c	3000.280	Haltebügel	Holding bracket	Etrier pour support
13d	3000.244	3000.244 Halter-Erweiterung	Holding device extension	Prolongateur de support
13e	3060.440	3060.440 Sauger 4 Stück	Suction bell 4 pcs.	Ventouses 4 pièces

Die Teileabbildung zeigt die mitgelieferten Einzelteile. Die Ersatzteilliste enthält auch Teile die davon abweichen können.
The illustration shows the individual parts supplied. The list of spare parts may also contain parts which deviate.
L'illustration indique les pièces individuelles utilisées. La liste de pièces détachées comporte des pièces pouvant différer de cette illustration.

9015	9020	Ersatzteilliste Abschäumer 9015,9020	List of spare parts Skimmer 9015,9020	Liste des pièces Ecumeur 9015, 9020
1	9015.140	Schaumtopf	Skimmer cup	Godet d'écumage
2	9020.140	Schaumwasserabführung	Foam extraction unit	Réacteur à évacuation directe
3	0214.150	Schaumtopfdeckel	Skimmer cup lid	Couvercle de godet
4	9010.100	Gehäuse	Housing	Corps d'écumeur
5	9010.360	Luftinstellschraube M8	Air regulator screw M8	Vis de réglage M8
6	9010.040	Hydrofoamer	Hydrofoamer	Hydrofoamer
7	3130.020	Deckel mit 4 Schlitzfen	Cover with four slots	Couvercle à 4 ouvertures
8	9010.300	Abdeckung mit Schiebendeckel	Cover with sliding cover	Couvercle frontal à coulisse
9	9010.350	Kappe auf Abdeckung	Cap with cover	Obturateur
10	9010.400	Muffe unter Abdeckung	Sleeve below cover	Pièce manchon
11	9010.200	Deckel für Sauger	Cover for aspirator	Couvercle pour ventouses
12	9010.700	Rohr mit Muffe	Tube with bushing	Tuyau et coude
13	0800.140	Patronenkern zu 800.22	Cartridge core to 800.22	Coeur de cartouche p.800.22
14	1075/2	Ablauf-Schlauch	Outlet hose	Tuyau d'évacuation
15	3130.250	Comline-Schäumer-Halter	Comline skimmer support	Support d'écumeur Comline
15a	3000.240	3000.240 Klemmhalter	Clamp holder	Attache de support
15b	1281.313	2 Schrauben+2Muttern M6	2 screw+2 nuts M6x16mm	2 vis+ 2 écrous M6x16mm
15c	3000.280	3000.280 Haltebügel	Holding bracket	Etrier pour support
15d	3000.244	3000.244 Halter-Erweiterung	Holding device extension	Prolongateur de support
15e	3060.440	3060.440 Sauger 4 Stück	Suction bell 4 pcs.	Ventouses 4 pièces

Die Teileabbildung zeigt die mitgelieferten Einzelteile. Die Ersatzteilliste enthält auch Teile die davon abweichen können.
The illustration shows the individual parts supplied. The list of spare parts may also contain parts which deviate.
L'illustration indique les pièces individuelles utilisées. La liste de pièces détachées comporte des pièces pouvant différer de cette illustration.

Classic DOC Skimmer

Teileabbildung • Illustration of parts • Illustration des pièces

9205/9210

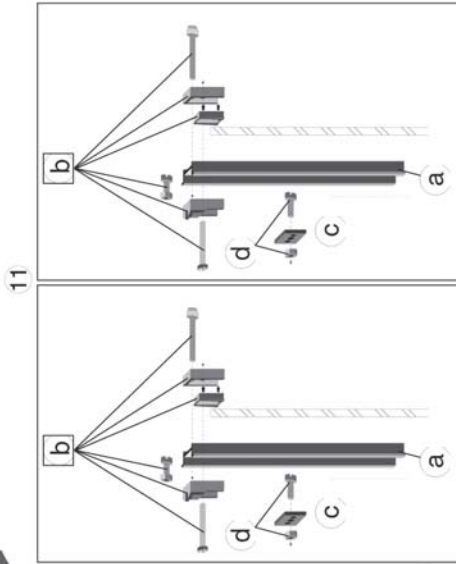
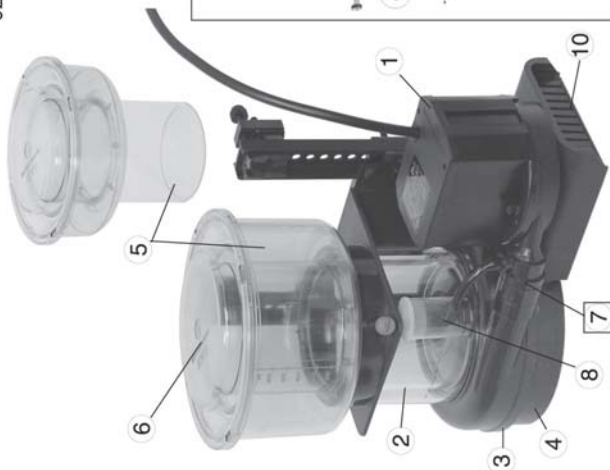

Ersatzteile Antriebseinheit • Spare parts of drive unit • Pièces équipement mobile



1 3000.600	Antriebseinheit	Drive unit	Equipage mobile
2 3000.620	Lagerbuchse	Bearing bush	Coussinet
3 3000.650	Lagerschale	Bearing shell	Coquille
4 3000.640	Antriebswelle	Drive shaft	Arbre d'entraînement
5 3000.660	2 Bremsbacken	2 Brake shoes	2 Mâchoires
6 3000.630	Magnetrotor	Magnetic rotor	Magnetorotor
7 3000.610	Lager oben	Upper bearing	Palier supérieur
8 3000.612	O-Ring, 13x2,5mm	O-ring seal, 13x2,5mm	Joint torique, 13x2,5mm

Ersatzteile Schäumerpumpen • Spare parts of skimmer pumps • Pièces pour pompes d'écumeurs

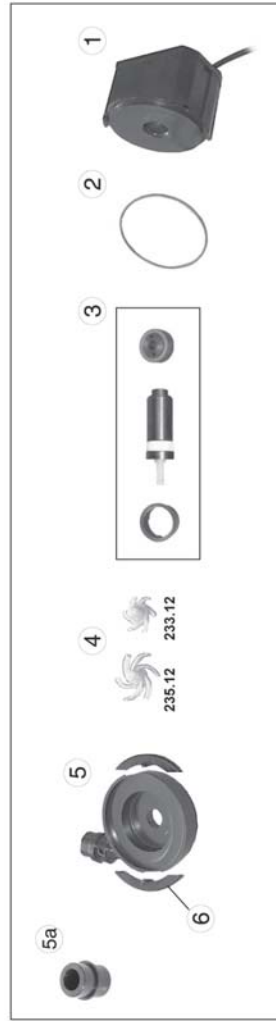

9005.040	9010.040	Hydrofoamer	Hydrofoamer
1 9005.015	9010.015	Motorblock	Hydrofoamer
2 3000.020	3000.020	O-Ring, 78x2,5mm	Bloc moteur
3 3000.600	3000.600	Antriebseinheit	Joint torique, 78x2,5mm
4 0233.120	0235.120	Kreisel	Equipage mobile
5 0235.130	0235.130	Kreiselgehäuse	Turbine HP
5a 3130.160	3130.160	Düse	Corps de pompe
6 0235.140	0235.140	2 Klammern	2 clips

9205	9210	Ersatzteilliste Abschäumer 9205, 9210	List of spare parts Skimmer 9205, 9210	Liste des pièces Écumeur 9205, 9210
1 9005.040	9010.040	Hydrofoamer	Hydrofoamer	Hydrofoamer
2 0230.660	0230.660	Abschäumer-Oberenteil	Skimmer casing	Boîtier
3 0230.050	0230.050	Scheibe	Disc	Disque
4 0225.040	0225.040	Unterteil	Skimmer housing, low	Partie inférieure
5 9005.140	0220.140	Schaumtopf	Skimmer cup	Godet d'écumage
6 0214.150	0214.150	Schaumtopfdeckel	Skimmer cup lid	Couvercle de godet
7 0230.350	0230.350	Düsenrohr	Pressure pipe	Lance
8 0230.490	0230.490	Schalldämpfer m. Schlauch	Silencer w air hose	Silencieux a. tuyau
8a 0235.484	0235.484	Kappe	Cap	Bouchon
8b 0230.491	0230.491	Kappe mit 6,5mm Bohrung	Cup with 6,5mm hole	Bouchon percé 6,5mm
9 3130.360	3130.360	Luftfeinstellschraube	Air regulator screw	Vis de réglage
10 0230.550	0230.550	Konsole	Pump support	Support de pompe
11 0230.250	0230.250	Schäumer-Halter	Skimmer support	Support écumeur
11a 3000.220	3000.220	Lochschiene	Mounting bar	Barre de montage
11b 3000.240	3000.240	Klemnhalter	Clamp holder	Attache de support
11c 3000.261	3000.261	Verbindungsstück ohne Gewinde	Plate without thread	Plaque sans filets
11d 0230.252	0230.252	2 Schrauben+2Mutt. M6x25	2 screw+2 nuts M6x25mm	2 vis+ 2 écrous M6x25mm

Nano DOC Skimmer / Nano cleaner / Nano pump

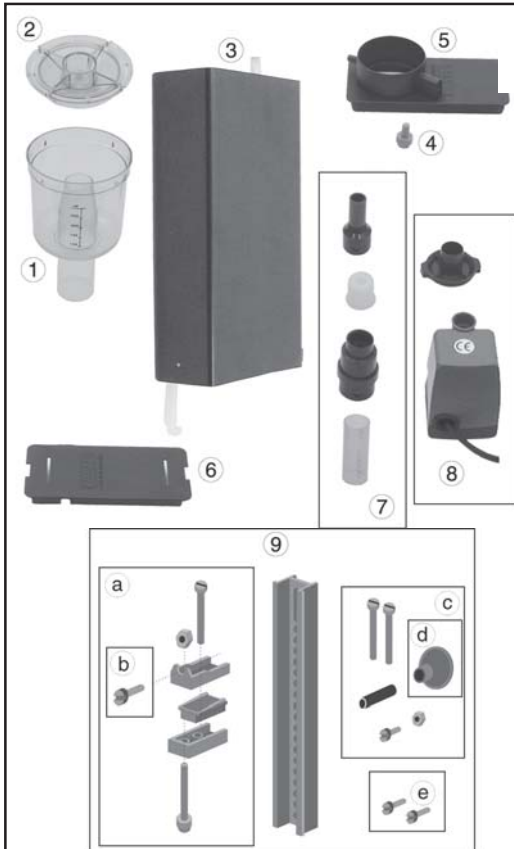

Teileabbildung • Illustration of parts • Illustration des pièces 9002
< 2008

	9002	Ersatzteilliste	List of spare parts	Liste des pièces
	1	3110.141 Schaumtopf	Skimmer cup	Godet d'écumage
	2	3110.150 Schaumtopfdeckel	Skimmer cup lid	Couvercle de godet
	3	9002.100 Gehäuse	Housing	Corps d'écumeur
	4	3130.360 Luftschraube	Airscrew	Vis d'air
	5	9002.030 Deckel oben	Upper lid	Couvercle supérieur
	6	3110.310 Deckel unten	Lower lid	Couvercle inférieur
	7	9002.400 Ausgangsrohr mit Düse	Outlet pipe with nozzle	Sortie avec buse d'injection
	8	0800.040 Nano pump	Nano pump	Nano pump
	9	9002.250 Nano-Halter	Nano holder	Support Nano
	9a	3000.240 Klemmhalter	Clamp holder	Attache de support
	9b	1281.313 1 Schraube + 1 Mutter M6	1 screw + 1 M6nut	1 vis + 1 écrous M6
	9c	3000.244 Haltererweiterung	Holding device extension	Prolongateur de support
	9d	3060.420 Sauger (3 Stück)	Suction cup (3 pcs.)	Ventouses (3 pièces)
	9e	3000.246 2 Schrauben M5x10mm	2 screws M5x10mm (.39 in.)	2 vis M5x10mm

Die Teileabbildung zeigt die mitgelieferten Einzelteile. Die Ersatzteilliste enthält auch Teile die davon abweichen können.

The illustration shows the individual parts supplied. The list of spare parts may also contain parts which deviate.

L'illustration indique les pièces individuelles utilisées. La liste de pièces détachées comporte des pièces pouvant différer de cette illustration.

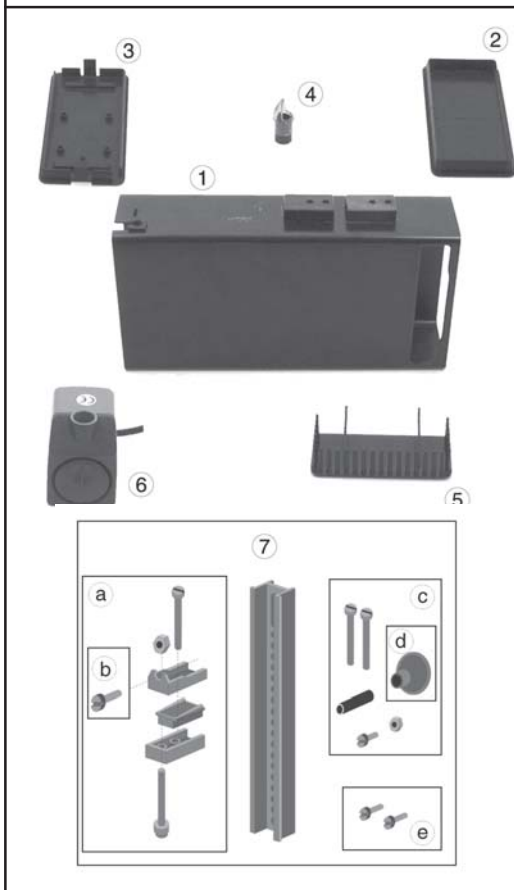

Teileabbildung • Illustration of parts • Illustration des pièces 3165
< 2008

	3165	Ersatzteilliste	List of spare parts	Liste des pièces
	1	3165.100 Gehäuse	Housing	Corps de filtre
	2	5024.020 Deckel oben	Upper lid	Couvercle supérieur
	3	3165.080 Deckel unten	Lower lid	Couvercle inférieur
	4	3165.40 Ausgangsrohr m. Strömungswinkel	Outlet tube with flow deflector	Sortie avec déflecteur
	5	5000.150.S Ansaugschutz	Protective grid	Grille d'aspiration
	6	0800.040 Nano pump	Nano pump	Nano pump
	7	9002.250 Nano-Halter	Nano holder	Support Nano
	7a	3000.240 Klemmhalter	Clamp holder	Attache de support
	7b	1281.313 1 Schraube + 1 Mutter M6	1 screw + 1 nut M6	1 vis + 1 écrou M6
	7c	3000.244 Haltererweiterung	Holding device extension	Prolongateur de support
	7d	3060.420 Sauger (3 Stück)	Suction cup (3 pcs.)	Ventouses (3 pièces)
	7e	3000.264 2 Schrauben M5x10mm	2 screws M5x10mm (.39 in.)	Vis M5 x 10mm

Die Teileabbildung zeigt die mitgelieferten Einzelteile. Die Ersatzteilliste enthält auch Teile die davon abweichen können.

The illustration shows the individual parts supplied. The list of spare parts may also contain parts which deviate.

L'illustration indique les pièces individuelles utilisées. La liste de pièces détachées comporte des pièces pouvant différer de cette illustration.

Teileabbildung • Illustration of parts • Illustration des pièces 800.04



	Ersatzteilliste	List of spare parts	Liste des pièces
1	0800.040 Nano Pump	Nano Pump	Nano Pump
2	0800.042 Antriebseinheit	Drive assembly	Entraînement
3	0800.048 Pumpendeckel	Pump cover	Couvercle de pompe
4	0800.043 Deckel auf Kreiselgehäuse	Cover on impeller housing	Couvercle de turbine
5	0800.047 Ausgangsrohr ø13mm	Outlet tube, diam. (.51 in.)	Sortie ø13mm
6	3165.400 Ausgangsrohr mit Strömungswinkel	Outlet tube with flow deflector	Sortie avec déflecteur
7	9002.400 Ausgangsrohr mit Düse	Outlet tube with nozzle	Sortie avec buse d'injection

Abschäumer • Skimmer • Ecumeur



233/2*
220/3



240/2*
240/3



* Artikelnummer vom Vorgängermodell
* Order no. for previous model

230/2*
230/3

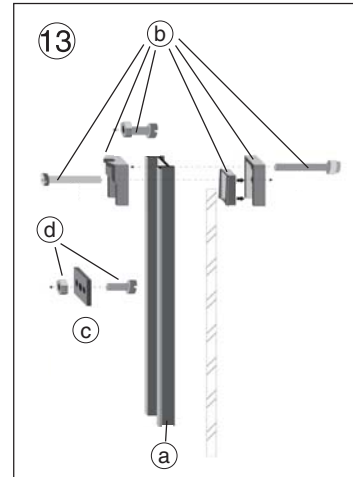

Teilleiste • List of Parts • Liste de pieces

	220/3	230/3	240/3	Abschäumer	Skimmer	Ecumeur
1	220.04 ¹	230.04 ²	240.04 ³	Pumpe mit 9	Pump with 9	Pompe avec 9
2	233.66	230.66	240.67	Abschäumer-Oberteil	Skimmer casing	Boîtier
3	230.05	230.05	230.05	Scheibe	Disk	Disque
4	225.04	225.04	225.04	Unterteil	Skimmer body lower part	Partie inférieure
5	233.14	220.14	245.14	Schaumtopf ohne 6/7	Skimmer cup without 6/7	Godet d'écumage sans 6/7
6			245.13	Schaumzylinder	Cylinder	Cylindre
7	214.15	214.15	214.15	Schaumtopfdeckel	Skimmer lid	Couvercle de godet
8	230.35	230.35	230.35	Düsenrohr	Pressure pipe	Lance
9	233.13	235.13	235.13	Kreiselgeh. mit 9A/9B	Impeller hous.with 9A/9B	Chambre de rotor avec 9A/9B
9a	233.135	235.135	235.135	Düse (weiß)	Nozzle (white)	Buse (blanc)
9b	233.165	230.165	230.165	Vordüse (braun)	Pre-nozzle (brown)	Pré-buse (brun)
10	230.49	230.49	230.49	Schalld. mit Lufts.	Silencer with air hose	Silencieux av. tuy. souple d'air
10a	235.484	235.484	235.484	Kappe	Cup	Bouchon
10b	230.491	230.491	230.491	Kappe	Cup	Bouchon
11	3130.36	3130.36	3130.36	Luftestellschraube	Air regulator screw	Vis réglage d'air
12	230.55	230.55	230.55	Konsole	Pump support	Support de pompe
13	230.25 ⁴	230.25 ⁴	230.25 ⁴	2 Halter	2 Holder	2 Support
13a	2x3000.22	2x3000.22	2x3000.22	Lochschiene	Mounting Bar	Barre de montage
13b	2x3000.24	2x3000.24	2x3000.24	Klemmhalter	Clamp holder	Attache
13c	2x3000.261	2x3000.261	2x3000.261	Verbindungsstück o. Ge.	Plate without thread	Plaque sans filets
13d	230.252	230.252	230.252	2 Schr.+2Mutt.M6x25 sw	2 screwM6x25 +2 nuts black	2 viss M6x25+ 2 écrou noir
13	233.12	235.12	235.12	Kreisel	Impeller	Turbine
14			7240.26 ⁵	Treiber	Driver	Driver
15			7410.602 ⁶	Transformator	Transformer	Transformateur

Artikelnummer vom Vorgängermodell:
Order no. for previous model:

¹ 233.02

² 235.02

³ 240.02

⁴ 2x3000.14 + 2x102.45

⁵ 240.24

⁶ 7400.60

TUNZE SYSTEM Abschäumer • Skimmer • Ecumeur

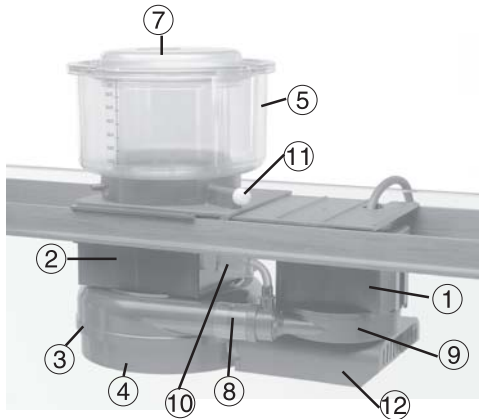

238/2*
225/3

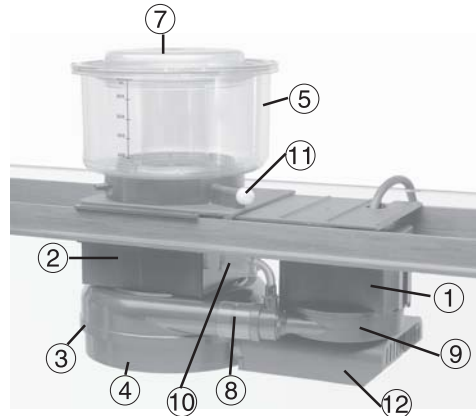

235/2*
235/3

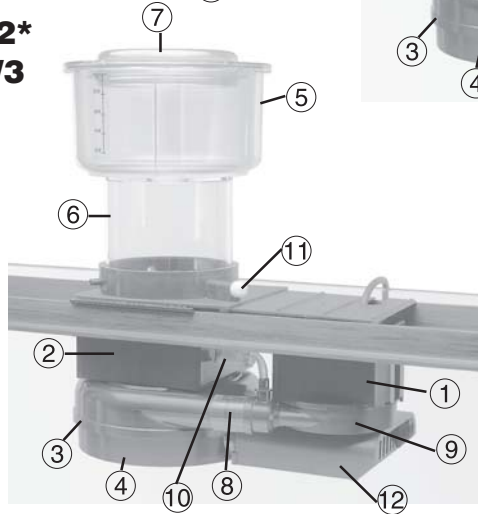

245/2*
245/3

* Artikelnummer vom Vorgängermodell
* Order no. for previous model

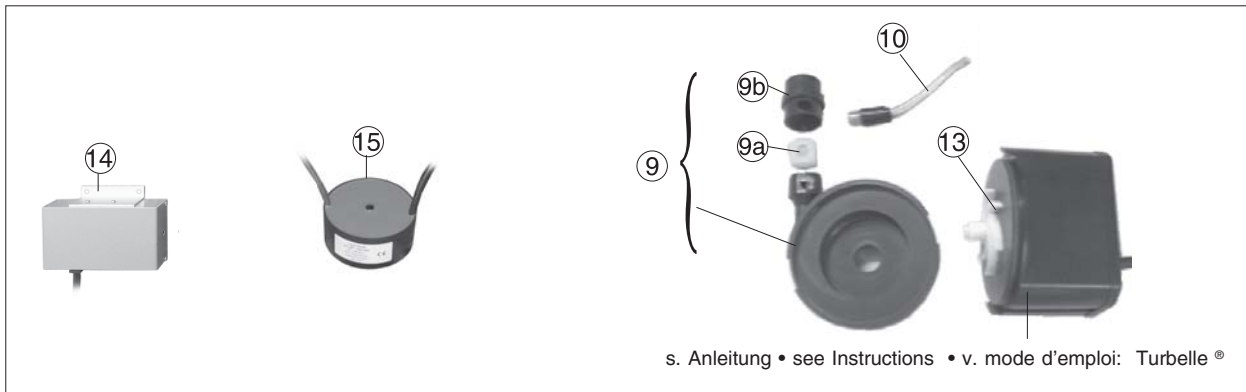

Teilleiste • List of Parts • Liste de pieces

	225/3	235/3	245/3	Abschäumer	Skimmer	Ecumeur
1	220.04 ¹	230.04 ²	240.04 ³	Pumpe mit 9	Pump with 9	Pompe avec 9
2	238.03	235.03	245.67	Abschäumer-Oberteil	Skimmer casing	Boîtier
3	230.05	230.05	230.05	Scheibe	Disk	Disque
4	225.04	225.04	225.04	Unterteil	Skimmer body lower part	Partie inférieure
5	233.14	220.14	245.14	Schaumtopf ohne 6/7	Skimmer cup without 6/7	Godet d'écumage sans 6/7
6			245.13	Schaumzylinder	Cylinder	Cylindre
7	214.15	214.15	214.15	Schaumtopfdeckel	Skimmer lid	Couvercle de godet
8	230.35	230.35	230.35	Düsenrohr	Pressure pipe	Lance
9	233.13	235.13	235.13	Kreiselgeh. mit 9A/9B	Impeller hous.with 9A/9B	Carter du rotor avec 9A/9B
9a	233.135	235.135	235.135	Düse (weiß)	Nozzle (white)	Buse (blanc)
9b	233.165	230.165	230.165	Vordüse (braun)	Pre-nozzle (brown)	Pré-buse (brun)
10	230.49	230.49	230.49	Schalld. mit Lufts.	Silencer with air hose	Silencieux av. tuy. souple d'air
10a	235.484	235.484	235.484	Kappe	Cup	Bouchon
10b	230.491	230.491	230.491	Kappe	Cup	Bouchon
11	3130.36	3130.36	3130.36	Luftinstellschraube	Air regulator screw	Vis réglage d'air
12	230.55	230.55	230.55	Konsole	Pump support	Support de pompe
13	233.12	235.12	235.12	Kreisel	Impeller	Turbine
14			7240.26 ⁴	Treiber	Driver	Driver
15			7410.602 ⁵	Transformator	Transformer	Transformateur

Artikelnummer vom Vorgängermodell:
Order no. for previous model:

- ¹ 233.02
- ² 235.02
- ³ 240.02
- ⁴ 240.24
- ⁵ 7400.60

ComLine Abschäumer • Skimmer • Ecumeur

3115*
3115/2
3116/2

3130*
3130/2
3131/2

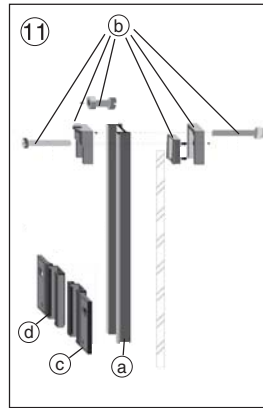

* Artikelnummer vom Vorgängermodell
* Order no. for previous model

Teilleiste • List of parts • Liste des pièces

	31152	31162	31302	31312	Abschäumer-Automat	Automatic Skimmer	Ecumeur automat.
1	3115.04 ¹	3115.04	230.04 ²	230.04	Ersatzpumpe mit 2 + 3	Pump with 2 + 3	Pompe avec 2 + 3
2	235.13	235.13	235.13	235.13	Kreiselgehäuse	Impeller housing	Chambre turbine
2a	235.135	235.135	235.135	235.135	Düse (weiß)	Nozzle (white)	Buse (blanc)
2b	230.165	230.165	230.165	230.165	Vordüse (braun)	Pre-nozzle (brown)	Pré-buse (brun)
3	233.12	233.12	235.12	235.12	Kreisel	Impeller	Turbine
4	3115.10	3116.10	3130.10	3131.10	Gehäuse	Housing	Boîtier
5	3130.482	3130.482	3130.482	3130.482	2 Schläuche + Kappe	2 hoses + cap	2 tuyaux + bouchon
6	3130.36	3130.36	3130.36	3130.36	Luftinstellschraube	Air regulating screw	Vis de réglage d'air
7	3115.20	3115.20	3115.20	3115.20	Deckel für Pumpenhalt.	Cover for pump	Couvercle de pompe
8	3166.07	3166.07	3166.07	3166.07	Sicherungsplatte	Retaining plate	Plaque de maintien
9	233.14	233.14	220.14	220.14	Schaumtopf o. Deckel	Skimmer cup without lid	Godet d'écumage
10	214.15	214.15	214.15	214.15	Schaumtopfdeckel	Skimmer cup lid	Couvercle de godet
11	3130.25 ³	3130.25	3130.25	3130.25 ³	Halter	Holder	Support
11a	2x3000.22	2x3000.22	2x3000.22	2x3000.22	Lochschiene	Mounting Bar	Barre de montage
11b	2x3000.24	2x3000.24	2x3000.24	2x3000.24	Klemmhalter	Clamp holder	Support
11c	3130.251	3130.251	3130.251	3130.251	Schiebeteil rechts	Sliding piece l/h	Attache droite
11d	3130.252	3130.252	3130.252	3130.252	Schiebeteil links	Sliding piece l/h	Attache gauche

Artikelnummer vom Vorgängermodell:
Order no. for previous model:

¹ 3115.03

² 235.02

³ 2x3000.14

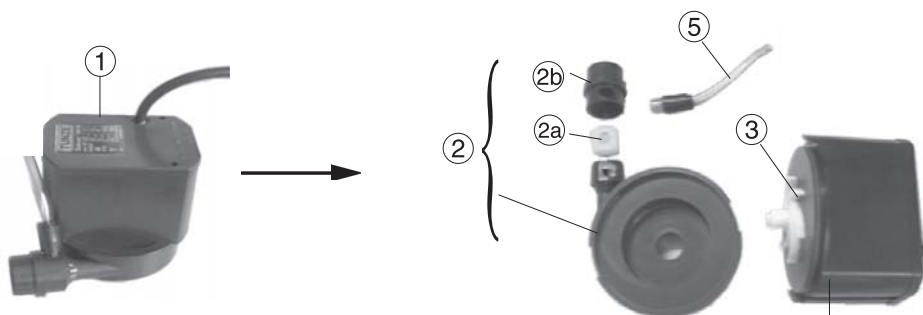

s. Anleitung • see Instructions • v. mode d'emploi: Turbelle ®

ComLine Abschäumer • Skimmer • Ecumeur

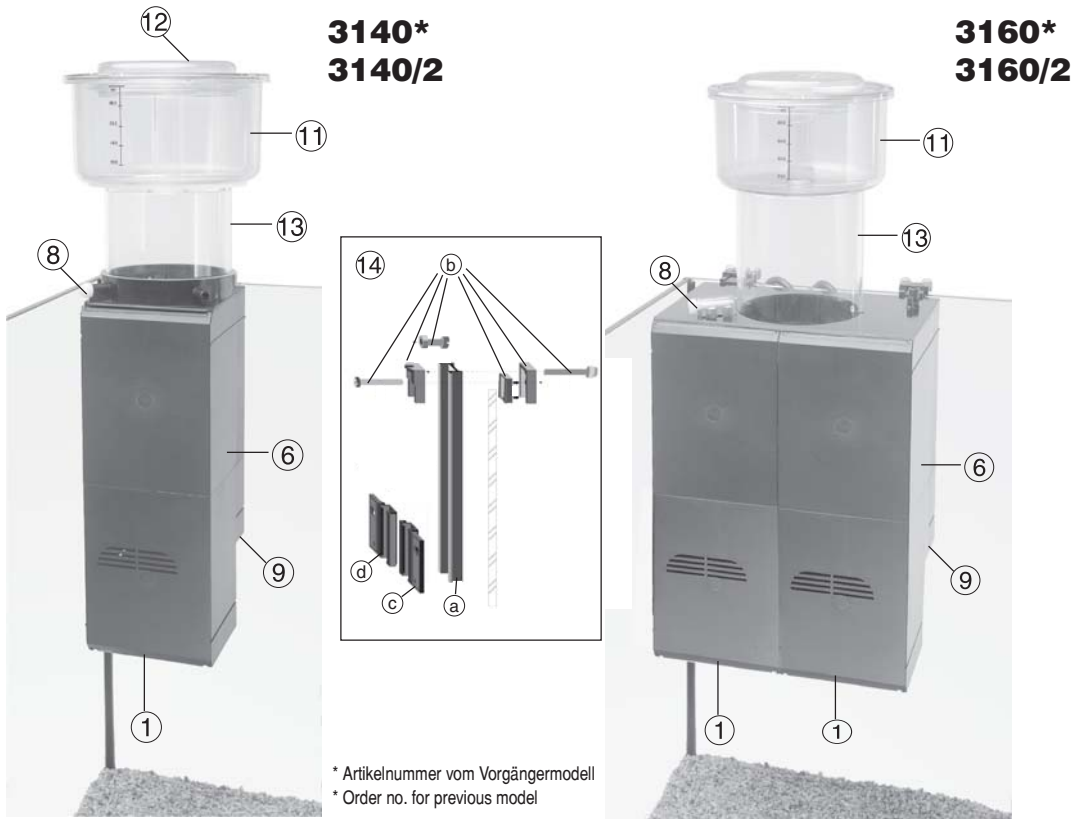

* Artikelnummer vom Vorgängermodell
* Order no. for previous model

Teileliste • List of parts • Liste des pièces

	3140/2	3160/2	Abschäumer-Automat	Automatic Skimmer	Ecumeur automatique
1	240.04 ¹	2x230.04 ²	Ersatzpumpe mit 4 + 5	Pump with 4 + 5	Pompe avec 4 + 5
2	7240.26 ³		Treiber	Driver	Driver
3	7410.602 ⁴		Transformator	Transformer	Transformateur
4	235.13	2x235.13	Kreiselgehäuse	Impeller housing	Chambre turbine
4a	235.135	2x235.135	Düse (weiß)	Nozzle (white)	Buse (blanc)
4b	230.165	2x230.165	Vordüse (braun)	Pre-nozzle (brown)	Pré-buse (brun)
5	235.12	2x235.12	Kreisel	Impeller	Turbine
6	3140.10	3160.10	Gehäuse	Housing	Boîtier
7	3130.482	3160.48	2 Schläuche + Kappe	2 hoses + cap	2 tuyaux + bouchon
8	3130.36	3160.36	Luftinstellschraube	Air regulating screw	Vis de réglage d'air
9	3115.20	2x3115.20	Deckel für Pumpenhalterung	Cover for pump	Couvercle de maintien
10	3166.07	2x3166.07	Sicherungsplatte	Retaining plate	Plaque
11	245.14	245.14	Schaumtopf ohne Deckel	Skimmer cup without lid	Godet d'écumage sans couv.
12	214.15	214.15	Schaumtopfdeckel	Skimmer cup lid	Couvercle de godet
13	245.13	3160.13	Schaumzylinder	Cylinder	Réacteur rehaussé
14	3130.25 ⁵	3130.25 ⁵	Halter	Holder	Support
14a	2x3000.22	2x3000.22	Lochschiene	Mounting Bar	Barre de montage
14b	2x3000.24	2x3000.24	Klemmhalter	Clamp holder	Support
14c	3130.251	3130.251	Schiebeteil rechts	Sliding piece l/h	Attache droite
14d	3130.252	3130.252	Schiebeteil links	Sliding piece l/h	Attache gauche

Artikelnummer vom Vorgängermodell:
Order no. for previous model:

- ¹ 240.02
- ² 235.02
- ³ 7240.25
- ⁴ 7400.60
- ⁵ 3000.14

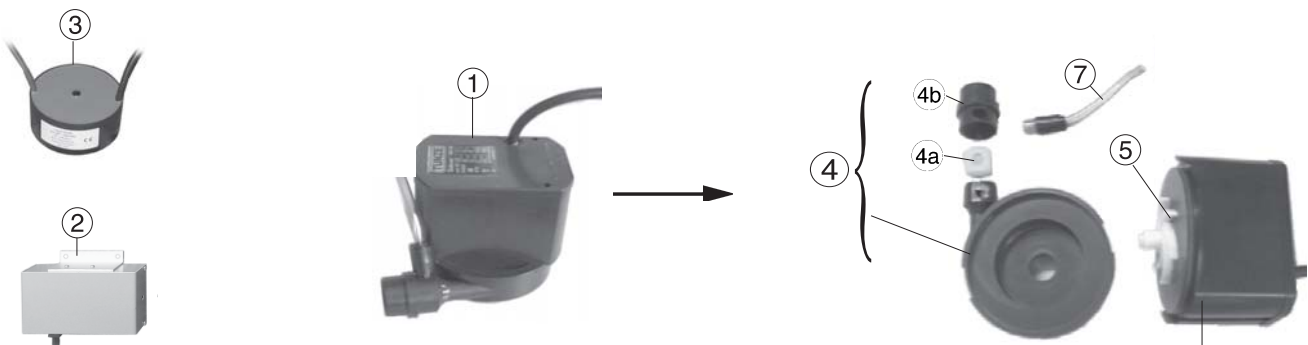

s. Anleitung • see Instructions • v. mode d'emploi: Turbelle®

Comline Calcium Automat 3170

Teileabbildung • Illustration of parts • Illustration des pièces 3170

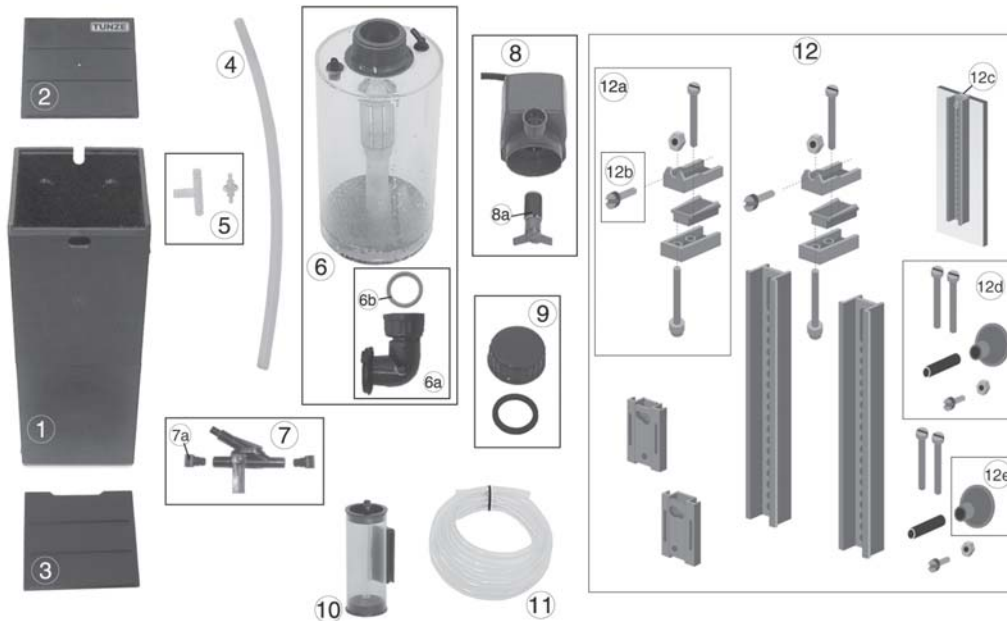

	3170	Ersatzteilliste	List of spare parts	Liste des pièces
	1	3170.100 Gehäuse	Housing	Corps conteneur
	2	3166.020 Schiebendeckel	Sliding cover	Couvercle
	3	3179.020 Schiebendeckel mit Ausschnitt	Sliding cover with cutout	Couvercle avec ouverture
	4	7072.200 Silikonschlauch ø4x7mm	Silicone hose, ø4x7mm (.15x.27in.)	Tuyau silicone ø4x7mm
	5	3170.300 Reduzier- u. T-Stück	Reducing adapter and T piece	Réducteur et pièce en T
	6	3170.200 Reaktor	Reactor	Réacteur
	6a	3170.134 Verbindungsstück mit O-Ring	Connecting unit with O ring seal	Pièce de raccordement avec joint
	6b	3000.612 O-Ring rot, 13x2,5mm	O-ring red, 13x2.5mm	Joint torique rouge, 13x2,5mm
	7	3170.460 Y-Abzweigung	Y- branch	Robinet Y
	7a	879.711 Biowasser-Verteilerdüse	Distribution nozzle	Buse de répartition bio
	8	800.040 Nano pump	Nano pump	Nano pump
	8a	800.042 Antriebseinheit	Drive assembly	Entraînement
	9	3174.112 Schraubdeckel u. Dichtung	Screw cap and seal	Bouchon à vis avec joint
	10	1572.200 Blasenähler	Bubble counter	Compte-bulles
	11	7072.300 PVC-Schlauch ø 4x6mm	PVC hose ø 4x6mm (.23x.35 in.)	Tuyau PVC ø 4x6mm
	12	3166.25 Comline Halter	Comline holder	Support Comline
	12a	3000.24 Klemmhalter	Clamp holder	Attache de support
	12b	1281.313 2 Schrauben + 2 Muttern M6	2 screws + 2 M6 nuts	2 vis + 2 écrous M6
	12c	3000.28 Haltebügel	Holding bracket	Etrier pour support
	12d	3000.244 Haltererweiterung	Holding device extension	Prolongateur de support
	12e	3060.42 Sauger (3 Stück)	Suction cup (3 pcs.)	Ventouses (3 pièces)

Osmolator Universal 3155



	3155	Osmolator Universal	Osmolator Universal	Osmolator Universal
	1	5017 Controller 5017	Controller 5017	Controller 5017
	2	5000.02 Dosierpumpe 9V	Metering pump 9V	Pompe de dosage
	3	5000.39 Schlauch 4x7mm/3m schw.	Hose 4x7mm/3m black	Tuyau 4x7mm/3m, noir
	4	5012.01 Netzteil 9V	Power supply unit w. 9V DC	Bloc d'alimentation 9V=
	5	2x3000.22 Lochschiene	Perforated rail	Barres de montage
	6	3155.10 Schiebeteil Sicherheitsens.	Sliding unit - safety sensor	Pièce coulissante Too high
	7	3155.20 Schiebeteil Arbeitssensor	Sliding unit - operating sens.	Pièce coulissante Level
	8	2x3000.24 Klemmhalter	Clamp holder	Attaches
	8a	3000.243 Schraubenset von (8)	Set of screws of (8)	Set visserie (8)
	9	3150.31 Halteplatte für Sensor	Retaining plate	Support pour palpeurs
	10	5000.24 Schlauchschelle	Hose clamp	Collier de serrage p.tuyau
	11	2x3000.27 Klebefestigung	Fixing for adhesion	Support à coller
	12	3155.25 Halter f. 3155 komplett (5-11)	Holder f. 3155 compl. (5-11)	Support p. 3155 (5-11)

Turbelle® stream II > 2008

Teileabbildung • Illustration of parts • Illustration des pièces



Teileabbildung • Illustration of parts • Illustration des pièces



6065.000	6085.000	6125.000	Ersatzteilliste Turbelle® stream	List of spare parts Turbelle® stream	Liste des pièces Turbelle® stream
1	6065.100	6085.100	6125.100	Motor block	Bloc moteur
2	6065.130	6065.130	6205.130	Propeller housing	Corps de pompe
3	6065.700	6065.700	6125.700	Drive unit	Entrainement
3a	6065.792	6065.792	6065.792	Scheibe für Antrieb	Rondelle d'entraînement
4	6065.510	6065.510	6065.510	Klemme	Pince
5	6065.500	6065.500	6205.500	Magnet Holder	Magnet Holder
6	6080.200	6080.200	6205.200	Schutzgitter	Grille de protection
7	6200.509	6200.509	6200.509	9 Elastikpuffer f. Magnet Holder	9 tampons pour Magnet Holder

6105.000	6205.000	6305.000	Ersatzteilliste Turbelle® stream	List of spare parts Turbelle® stream	Liste des pièces Turbelle® stream
1	6105.100	6205.100	6305.100	Motor block	Bloc moteur
2	6065.130	6205.130	6305.130	Propeller housing	Corps de pompe
3	6105.700	6205.700	6305.700	Antriebsseinheit	Entrainement
3a	6065.792	6065.792	6065.792	Scheibe für Antrieb	Rondelle d'entraînement
4	6065.510	6065.510	6065.510	Klemme	Pince
5	6065.500	6205.500	6205.500	Magnet Holder	Magnet Holder
6	6101.240			Nezteil 12-24V DC	Alimentation 12-24V DC
7		6300.240	6300.240	Nezteil 24V DC	Alimentation 24V DC
8	6080.200	6205.200	6205.200	Schutzgitter	Grille de protection
9	6200.509	6200.509	6200.509	9 Elastikpuffer f. Magnet Holder	9 tampons pour Magnet Holder

851 / 852 + 851.76 / 851.76

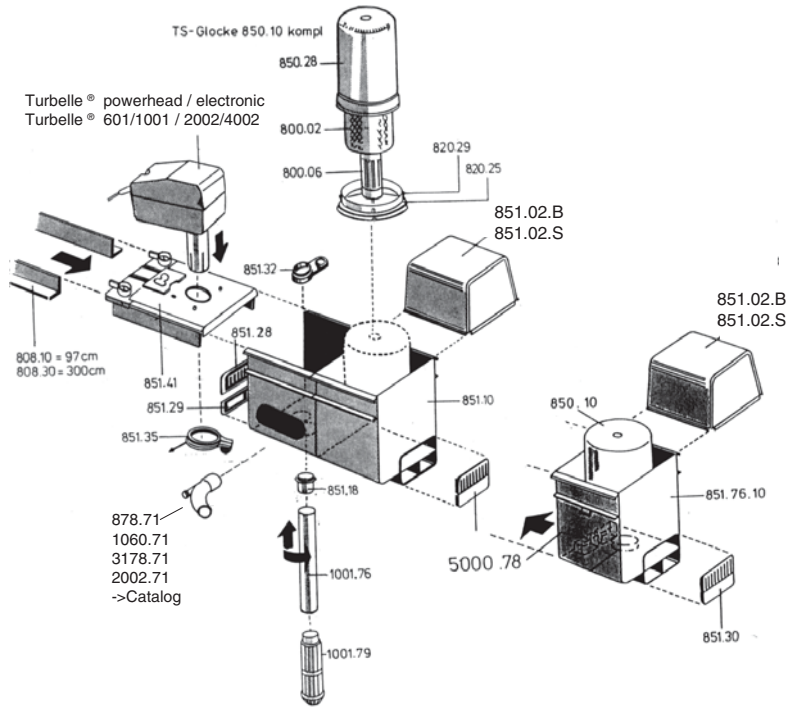

1651 / 1652 + 1651.76

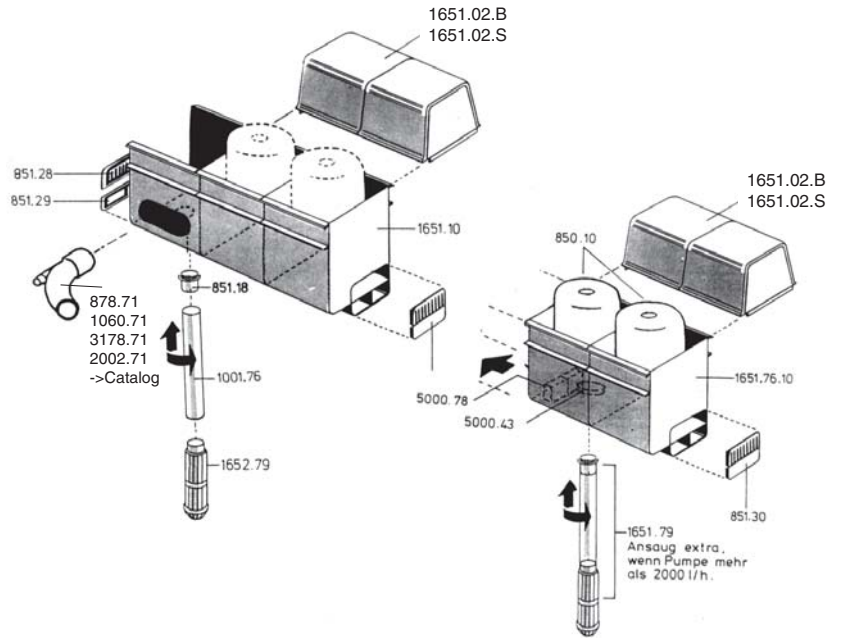

853 / 1653

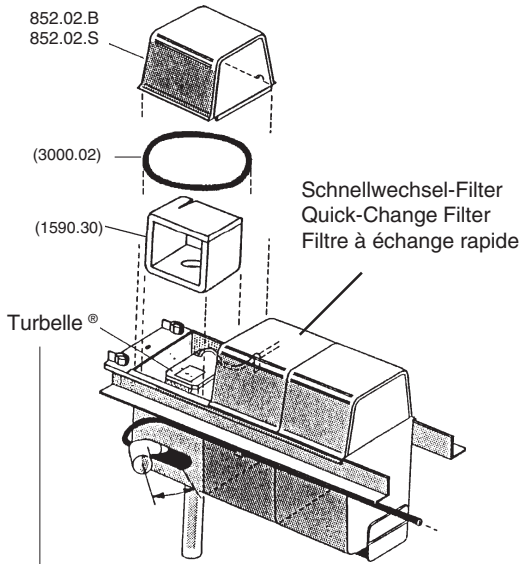

Turbelle® powerhead / electronic
Turbelle 2002/4002 + 851.42
-> Catalog

weitere Informationen siehe
other Informations see
d'autres informations voir

852/1652

TUNZE SYSTEM Bio-Reaktor • Bio-Reactor • Réacteur biologique
Hydorkultur-Reaktor • Hydroponic Reactor • Réacteur a hydroculture

876

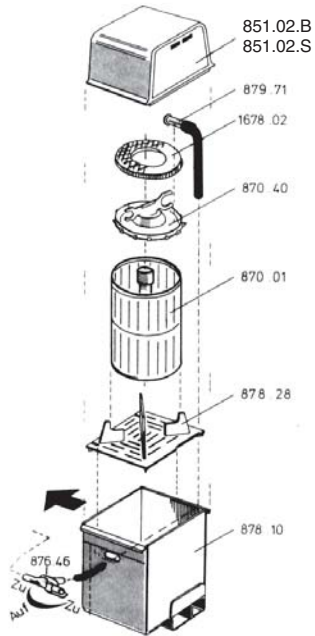

1676

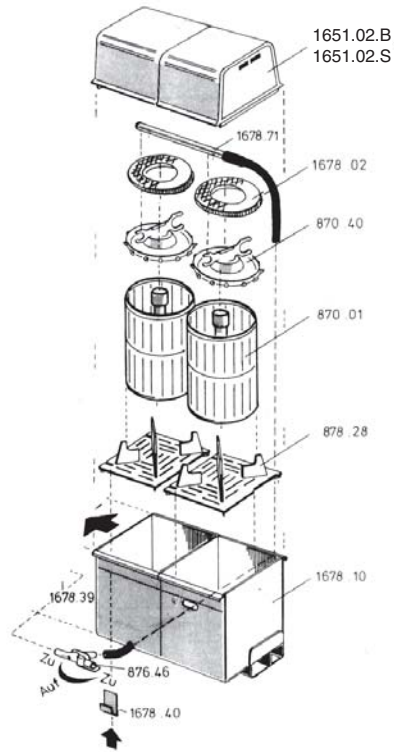

879

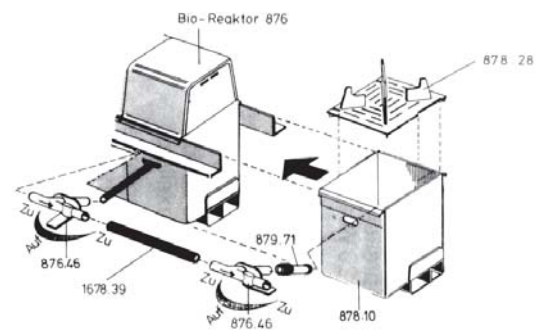

1679

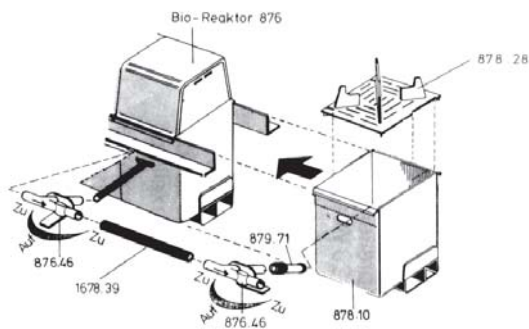

KOGAPUR reverse osmosis

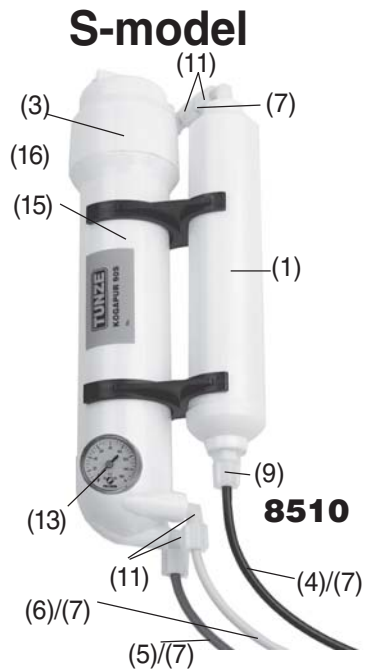
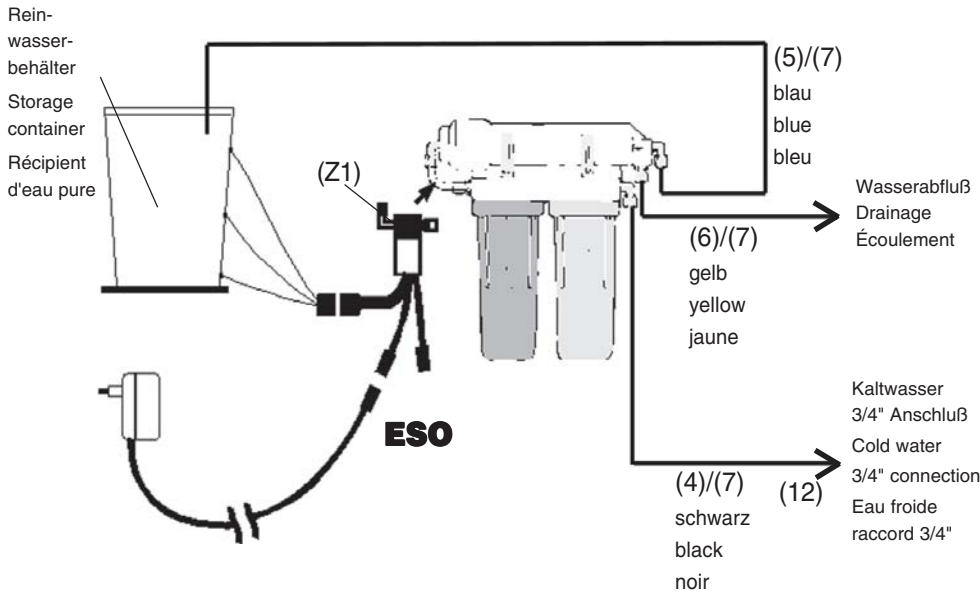

Umrechnungstabelle psi - bar

50 psi	- 3,3 bar
60 psi	- 4,0 bar
70 psi	- 4,6 bar
80 psi	- 5,3 bar
90 psi	- 6,0 bar
100 psi	- 6,6 bar

M-model

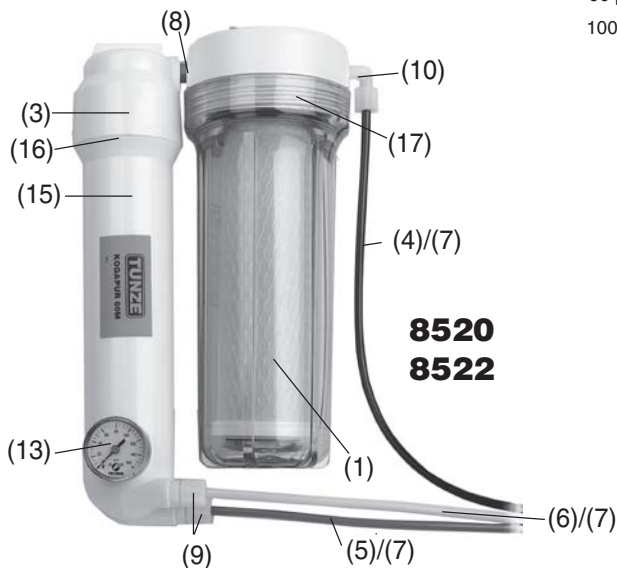

L-model

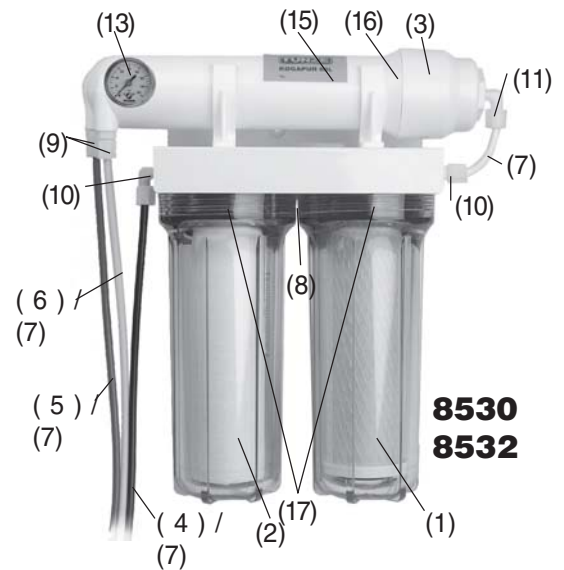

	8510	8512	8520	8522	8530	8532	8534	Teilleiste	List of parts	Liste de pièces
1	8512.100	8512.100	8522.120	8522.120	8522.120	8522.120	8522.120	Kohle/Sedimentfilter	Carbonfilter	Carbonfilter
2					8522.100	8522.100	8522.100	Feinfilter 1µm	Filter 1µm	Filtre 1µm
3	8550.500	8552.500	8550.500	8552.500	8550.500	8552.500	8554.500	Membrane	Membrane	Membrane
4								Speisewasser (schw.)	Feed water (black)	eau purifiée (noir)
5								Reinwasser (blau)	pure water (blue)	eau purifiée (bleu)
6								Solewasser (gelb)	drain water (yellow)	Eau de refus (jaune)
7	8556.000	8556.000	8556.000	8556.000	8556.000	8556.000	8556.000	Druckschlauch (weiß)	pressure hose (white)	Tuyau pour (blanc)
8	8532.010	8532.010	8532.010	8532.010	8532.010	8532.010	8532.010	Übergang 1/4"	1/4" transition	1/4" transition
9	8532.040	8532.040	8532.040	8532.040	8532.040	8532.040	8532.040	Übergang 1/8"	1/8" transition"	1/8" transition
10	8532.020	8532.020	8532.020	8532.020	8532.020	8532.020	8532.020	Winkel 1/4"	1/4" elbow"	1/4" angle
11	8532.030	8532.030	8532.030	8532.030	8532.030	8532.030	8532.030	Winkel 1/8"	1/8" elbow"	1/8" angle
12	8557.000	8557.000	8557.000	8557.000	8557.000	8557.000	8557.000	Verschraubung 3/4"	3/4" nylon nipple	3/4" nylon nipple
13	8532.050	8532.050	8532.050	8532.050	8532.050	8532.050	8532.050	Manometer	press. gauge	Manomètre
14	8532.060	8532.060	8532.060	8532.060	8532.060	8532.060	8532.060	Schrauben 3,2x17	Screw 3,2x17	Vis 3,2x17
15	8550.520	8552.520	8550.520	8552.520	8550.520	8552.520	8554.520	Kapillare 25% Rate	Capillary 25% rate	Capillary 25% rate
16	8532.070	8532.070	8532.070	8532.070	8532.070	8532.070	8532.070	O-Ring	O-ring	O-ring
17			8532.080	8532.080	8532.080	8532.080	8532.080	O-Ring	O-ring	O-ring
								Zubehör (extra best.)	Access. (order sep.)	Access. (com. dep.)
Z1	8540.000	8540.000	8540.000	8540.000	8540.000	8540.000	8540.000	ESO Wasserst. Kontr.	ESO Water level con.	

TUNZE® Total price list with spare parts - EURO

The deliveries are made in compliance with our respectively applicable terms of delivery and payment. Prices in €. Valid as from February 01, 2010. Subject to alterations.

Kit	Designation	Net sales price	Art. No.	Designation	Net sales price
TS24	Turbelle® stream Kit TS24	648,18	0210.045	Impeller housing	6,09
TS48	Turbelle® stream Kit TS48	1105,32	0210.049	Suction cups 4 pcs.	2,89
0015.000	Skimmer Kit 15	534,00	0210.165	Pre-nozzle	6,21
0016.000	Compact Kit 16	737,67	0210.491	Cup with 4,6mm hole	1,55
0018.000	Compact Kit 18	1224,00	0214.150	Skimmer cup lid	11,50
0018.700	Compact Kit 18.7	1352,52	0220.015	Motor block for 220.04	45,52
0021.000	Compact Kit 21	515,00	0220.040	Pump for skimmer	112,31
0068.000	Calcium Dispenser Kit 68	229,55	0220.140	Skimmer cup	39,36
0075.000	Kit 75	709,03	0220.400	Aquarium tongs	25,04
0079.000	Kit 79	514,79	0220.510	Protective gloves	4,82
Information media			0220.521	Rough surface, 77 x 59 mm (3.0 x 2.3 in.)	1,94
0085.000_A	Saltwater Aquarium	10,57	0220.522	Magnet. f. 220.55/54	10,28
0090.000	TUNZE catalogue - German / •	2,52	0220.526	Pile fabric surface, 77 x 59 mm (3.03 x 2.3 in.)	1,34
0090.000_A	TUNZE catalogue - English / \$US	2,52	0220.530	Power Magnet 220.53	14,21
0090.000_C	TUNZE catalogue Spanish / •	2,52	0220.540	Power Magnet 220.54	18,97
0090.000_E	TUNZE catalogue - English	2,52	0220.550	Power Magnet 220.55	93,96
0090.000_F	TUNZE catalogue - French / •	2,52	0220.558	Felt on the outside, 77 x 59 mm (3.03 x 2.3 in.)	3,09
0090.000_G	TUNZE catalogue - English / £	2,52	0220.560	Power Magnet 220.56	175,50
0090.000_H	TUNZE catalogue - Hungarian / •	2,52	0220.568	Fleece for acrylic panes	1,15
0090.000_I	TUNZE catalogue - Italian / •	2,52	0220.570	Power Magnet 220.57	376,29
0090.000_O	TUNZE catalogue Spanish / •	2,52	0220.571	Rough surface, 115 x 77 mm (4.5 x 3.0 in.)	4,70
0090.000_R	TUNZE catalogue - Russian	2,52	0220.572	Felt on the outside, 115 x 77 mm (4.5 x 3.03 in.)	7,74
0090.000_S	TUNZE catalogue Spanish / •	2,52	0220.700	Cleaning set	41,34
0091.000	Spare parts catalogue - German / •	1,68	0220.701	1/8" Brush	3,80
0091.000_A	Spare parts catalogue - English / \$US	1,68	0220.702	1/4" Brush	2,50
0091.000_E	Spare parts catalogue - English / •	1,68	0220.703	3/4" Brush	2,70
0091.000_F	Spare parts catalogue - French / •	1,68	0220.704	Bottle brush	3,80
0091.000_G	Spare parts catalogue - UK / £	1,68	0220.705	Bristle brush	1,80
0097.000	DVD: TUNZE Aquarientechnik GmbH	8,23	0220.706	TUNZE towel	9,10
0097.500	DVD: TUNZE Introduces (PAL)	8,23	0220.707	Pick tool	2,60
0097.500_A	DVD: TUNZE Introduces NTSC	8,61	0220.708	Screwdriver	5,50
0100/3_A	Aquarium Ecology, English	14,52	0220.709	Instructional DVD	6,70
Art.No.			0220.710	Citric acid	4,70
0102.400	Universal clamp V4A	11,93	0220.711	Squirt applicator	2,80
0102.404	Screw knob	0,90	0225.040	Skimmer housing, low	14,37
0102.407	Disc	1,00	0225.390	Air hose	1,23
0102.410	Mounting bracket	6,79	0225.460	Air pressure pipe	3,64
0102.430	Screw M6x12 V4A	0,75	0225.481.S	Cap f. silencer	0,69
0102.450	Mounting clamp	7,19	0230.015	Motor block for 230.04	80,46
0102.780	Connecting sleeve	1,39	0230.040	Turbelle® Powerhead -> 9010.04	140,01
0104.150	Impeller bearing	1,85	0230.050	Disc	9,40
0104.180	Screw connection	2,25	0230.101	Screw M5x6mm, with	1,41
0104.190	Screw M3x10 V2A	0,70	0230.165	Pre-nozzle	6,21
0104.241	Clip	1,05	0230.250	Skimmer support	10,34
0104.250	Repair kit	5,08	0230.252	2 screw+2 nuts M6x25mm	1,71
0104.710	Tangit, 125 g (4.4 oz.) tube	6,51	0230.350	Pressure pipe	2,04
0104.720	Silicone, 75 ml (2.5 oz.)	6,23	0230.490	Silencer w.air hose	7,86
0104.730	Instant adhesive	4,67	0230.491	Cup with 6,5mm hole	1,55
0104.740	Coral Fix - 112 g (4 oz.)	8,30	0230.550	Pump support	15,49
0104.790	Strainer, 7cm (2.7 in.)	5,26	0230.660	Skimmer casing	42,93
0106.170	Impeller	5,87	0231.020	Return pump	38,79
0110.010	Screw M4x6 PA	0,82	0233.010	Motor block for 233.02	51,05
0110.030	Thermostat	5,82	0233.120	Impeller	7,14
0110.090	Fan	2,06	0233.130	Impeller housing	29,40
0110.114	Wire protect.sleeve	1,38	0233.135	Nozzle	5,04
0110.130	Shaft with pinion	4,39	0233.140	Skimmer cup w. over	35,42
0110.140	Thrust washer	1,66	0233.165	Pre-nozzle	5,97
0110.260	Motor bearing	10,76	0233.660	Skimmer casing	35,77
0121.130	Shaft with pinion	8,44	0235.010	Motor block for 235.02	80,46
0121.131	Shaft	4,31	0235.120	HP Impeller	7,14
0121.160	Impeller housing	21,31	0235.130	Impeller housing	31,01
0121.170	Impeller	7,43	0235.135	Nozzle	5,25
0141.140	Thrust washer, 2 pcs.	1,20	0235.140	2 clips	2,87
0141.150	Impeller bearing, 2pc	4,82	0235.480	Silencer	7,86
0141.160	Impeller housing	21,31	0235.481	Cup H14, ø 26mm	1,10
0141.170	Impeller	9,07	0235.484	Cap	1,10
0141.180	Intake fitting	9,13	0240.010	Motor block for 240.02	65,03
0200.000	Nano Reefpack 200	142,45	0240.015	Motor block for 240.04	65,03
0210.040	Replacement pump	32,09	0240.020	Pump for skimmer ->240.04	194,13
0210.042	Drive unit for 210.04	6,21	0240.040	Pump for skimmer	194,13
0210.044	Upper bearing 2pcs. for 210.04	1,80	0240.484	Reducing adaptor for hose	0,87
			0245.140	Skimmer cup w. over	62,60
			0300.000	Cartridge filter 300	9,17
			0300.020	Filter cartridges, 75 mm (2.9 in.), 10 pcs.	12,13



Total price list with spare parts - EURO

Art. No.	Designation	Net sales price	Art. No.	Designation	Net sales price
0300.060	Stainer	3,15	0875.950	GRANOVIT	12,13
0305.120	Rotor,shaft+bearing	6,90	0875.960	GRANOVIT	65,51
0312.344	Glue-in nipple for hose, diam. 9 mm (.35 in.)	0,84	0876.460.S	Branch connec.f.hose	3,18
0320.000	Pot-type filter 320	17,85	0878.100.S	Bio reactor box	21,98
0320.260	Strainer	3,01	0878.280.S	Strainer bottom	4,90
0320.280	Pot for 320	9,76	0878.710	Bio connection for 805	4,43
0370.000	Refillable cartridge 370	11,50	0879.710.S	Bio tube	2,11
0390.040	Union for hose, diam. 6x9 mm (.23 x .35 in.)	0,72	0879.711	Distribution nozzle	0,65
0390.460	Y branch	3,57	0880.900	Calcium carbonate	29,58
0505.000	Reefpack 505	433,21	0880.901	Calcium carbonate	3,09
0505.110	O-ring seal	1,20	0880.950	Calcium carbonate	17,84
0505.120	Rotor,shaft+bearing	7,10	0880.960	Calcium Carbonate	79,53
0600.015	Motor block	28,97	0910.000	Quickphos 750 ml (25 oz.)	16,56
0602.120	Impeller	4,39	0920.000	Silphos 750 ml (25.4 oz.)	27,23
0602.400	Air draw nozzle	6,90	0930.000	Zeolite 750 ml (25 oz.)	11,33
0605.000	Riverpack 605	250,23	0940.000	Carbophos 750 ml (25.3 oz.)	14,93
0700.130	Impeller housing	21,31	0950.000	NanoChem 300 ml (10 oz.)	10,70
0800.000	Cartridge filter 800	14,13	1000.015	Motor block	36,32
0800.010	Filter cartridges,135 mm (5.3 in.), 5 pcs.	8,35	1001.060	2 Screw M 3x30 V2A	0,84
0800.015	Motor block	40,32	1001.102	Clamping ring	3,43
0800.030	Carbon floss cartridge, 135 mm (5.3 in.), 1 pc.	3,50	1001.150	Impeller bearing	3,43
0800.040	Nano pump	32,09	1001.160	Impeller housing	16,02
0800.042	Drive unit for 800.04 (50 Hz)	6,24	1001.240	Cable clamp	1,34
0800.043	Cover on impeller housing	4,08	1001.250	Repair kit	6,21
0800.047	Outlet pipe, diam. 13 mm (.51in.)	2,45	1001.400	Air venturi	5,54
0800.048	Pump cover	4,31	1001.740	Overflow tube	16,45
0800.060	Strainer	5,97	1001.741	Glueing nipple D=7/11	0,85
0800.070	Screw cap for PAF	2,90	1001.760	Pipe for Turbelle®	3,91
0800.080	Bracket	3,33	1001.770	Flow deflector	2,36
0800.140	Foam cartridge	2,80	1001.780	Bushing, diam. 21/25 mm (.82/.98 in.)	1,55
0800.220	Cartridge filter mat	1,88	1001.790	Strainer, 12 cm (4.7 in.)	6,79
0802.010	Motor block for 802	51,05	1001.800	T-piece	4,17
0805.000	Turbelle® e-jet 805	71,12	1002.120	Impeller	4,39
0805.015	Motor block	73,17	1002.150	Reducer	1,60
0805.700	Drive unit	20,04	1002.400	Air draw nozzle	5,54
0808.100	TS mounting bar - 97 cm (38.1 in.)	13,97	1005.000	Turbelle® e-jet 1005	57,90
0808.150	TS mounting bars - .97 m (38.1 in.) / pack of 5	60,67	1005.015	Motor block	73,17
0820.000	Pot-type filter 820	23,97	1005.120	Rotor,shaft+bearing	7,50
0820.250	Cover f. F320/820	5,39	1005.700	Drive unit	20,04
0820.260	Strainer	5,97	1073.000	Inlet hose and fittings	48,68
0820.280	Pot for 820	13,69	1073.008	Recirculation Pump Silence.	24,83
0820.290	Return stop	1,67	1073.020	Recirculation Pump Silence.	60,00
0850.100.S	TS bell compl.	20,73	1073.022	Cover with O ring seal	5,50
0850.250.S	Cover f. TS bell	5,49	1073.023	Suction housing	7,00
0850.280.S	TS bell	12,71	1073.024	Housing locking bar	6,05
0851.020.S	TS lid black	10,63	1073.025	4 suction cups + 2 hose supports	4,65
0851.060	Screw M 6x25	0,80	1073.027	Drive unit with bearing	15,40
0851.100.S	TS cover	32,46	1073.040	Recirculation Pump Silence.	101,15
0851.110	TS-cover with stage	13,83	1073.041	Screw cap 3/4 in., 10 bar (145 psi)	3,06
0851.180.S	TS screw connector	2,62	1073.042	Drive unit for 1073.03/.04 old	20,04
0851.280.S	Overflow grid	1,44	1073.043	Impeller housing for 1073.03/.04 old	22,44
0851.290.S	Cap	1,30	1073.044	Screwed socket with O ring seal	4,08
0851.300.S	Grid with cap	1,76	1073.047	Drive unit with bearing	35,37
0851.320.S	Adapter	2,16	1073.082	Cover with O ring seal	6,24
0851.400.S	Holder for TS mounting bar	8,01	1073.083	Suction housing	7,00
0851.440	Disc	0,85	1073.084	Housing locking bar	6,05
0851.450.S	TS heater&electrode holding device	9,41	1073.085	4 suction cups + 2 hose supports	4,65
0851.760.S	Quick-change filter extension	41,69	1073.087	Drive unit with shaft	6,24
0851.761.S	TS-Expansion box	25,29	1073.090	Master electronic 1073.090	263,97
0870.000	Refillable Cartridge 870	15,52	1073.091	3 O-rings seal Master 1073.09	5,10
0870.010	Bio cartidge	9,07	1073.092	Drive unit, impeller f. 1073.09	37,50
0870.020	Cover for 870/1670	1,40	1073.093	Impeller housing 1073.09	35,70
0870.400.S	Cover with clip	5,10	1073.094	Ceramic shaft with holder	23,28
0870.900	Filter Carbon	45,35	1073.095	Hose adapter DN38, 1"1/2G	4,59
0870.901	Filter carbon	4,92	1073.096	Strainer	8,74
0870.950	Filter Carbon	28,47	1073.142	Drive unit with impeller for 1073.14	32,64
0870.960	Filter Carbon	177,92	1073.143	Impeller housing 1073.14	35,70
0871.000	Wadding Refillable Cartridge 871	15,48	1073.162	Drive unit with impeller for 1073.16	32,64
0872.000	Micro wadding, 10 x 60 g (2.1 oz.)	25,08	1073.163	Impeller housing 1073.16	35,70
0872.010	Micro wadding, 60 g (2.1 oz.)	2,78	1073.500	Hose,diam.25 x200mm	3,06
0872.050	Micro wadding, 5 kg (176 oz.) sack	80,77	1073.600	Clamp	2,65
0873.000	Macro wadding, 10 x 250 g (8.8 oz.)	40,77	1074.100	Housing from 1074	57,75
0873.010	Macro wadding, 250 g (8.8 oz.)	4,54	1074.200	Cover	11,00
0875.900	GRANOVIT	18,92	1074/2	Overflow Box	91,58
0875.901	GRANOVIT	2,30	1075.050	Outlet hose a. clamp 1m/D.40mm	14,68



Total price list with spare parts - EURO

Art. No.	Designation	Net sales price	Art. No.	Designation	Net sales price
1075.500	Outlet filter	49,60	3000.300	Set 3000.07+3000.08	7,72
1075/2	Outlet hose	29,36	3000.400	Set 3000.09+3000.10	8,03
1076.150	Protective grid	7,06	3000.500	Internal parts Turbelle®	23,80
1076/2	Wall Overflow	82,99	3000.600	Drive unit	20,04
1077.000	Central Overflow	82,99	3000.610	Upper bearing	1,13
1077.100	Screw connection, pipe and hose	44,38	3000.612	O-ring seal, 13x2.5mm	1,10
1200.010	Motor block for 1200	80,46	3000.620	Bearing bush	3,22
1200.015	Motor block	73,17	3000.630	Magnetic rotor	11,80
1200.150	Bushing, outside diam. 25 mm (.98 in.)	2,02	3000.640	Drive shaft	4,67
1201.130	Impeller housing	21,11	3000.650	Bearing shell	3,22
1205.000	Turbelle® e-jet 1205	114,80	3000.660	2 Brake shoes	1,43
1205.015	Motor block	73,17	3000.780	Bushing, diam. 25/28 mm (.98 / 1.1 in.)	1,83
1205.700	Drive unit	20,04	3001.400	Air draw nozzle	7,35
1278.460	Union for hose, diam. 9x12 mm (.35 x .47 in.)	5,68	3005.000	Turbelle® e-jet 3005	100,00
1281.313	2 screw+2 nuts M6x16mm	1,63	3005.015	Motor block	73,17
1282.150	Bushing - outside diam. 25 mm (.98 in.)	2,76	3005.130	Motor block cover	73,17
1500.120	Impeller	4,39	3005.700	Drive unit	20,04
1500.130	Impeller housing	21,31	3005.740	Bearing and attenuation disk	73,17
1560.060	Strainer	13,88	3060.400	Bracket	2,48
1572.200	Bubble counter	11,07	3060.410	Suction cup holder	4,57
1590.300.S	Insulation mat	4,15	3060.420	Suction bell 3 pcs.	1,34
1600.000	Cartridge filter 1600	21,35	3060.440	Suction bell 4 pcs.	1,77
1600.010	Spare filter cartridge, 225 mm (8.8 in.), 5 pcs.	11,56	3060.450	Silencer holder for old Turbelle®	11,03
1600.015	Motor block	44,16	3060.460	Silencer holding device	11,03
1600.030	Carbon floss cartridge, 225 mm (8.8 in.), 1 pc.	6,24	3060.500	Set 3060.40+3060.41	5,95
1600.060	Strainer	12,18	3110.030	Cover for 3110/(2)	6,64
1605.000	Turbelle® e-jet 1605	71,20	3110.141	Skimmer cup 300 ml (10.1 f oz.)	9,76
1605.015	Motor block	73,17	3110.150	Skimmer cup lid	5,39
1605.700	Drive unit	20,04	3110.310	Cover with slots	5,54
1651.020.S	TS-Cover double black	18,25	3110.480	Hose with nipple	1,50
1651.761.S	TS-Box (empty)	42,02	3110.490	Hose with nipple	1,50
1652.790	Strainer, 17 cm (6.6 in.)	9,23	3115.010	Motor block	46,07
1670.000	Refillable cartridge 1670	26,73	3115.015	Motor block for 3115.04	45,52
1674.291	Grid with cap	1,94	3115.040	Turbelle® Powerhead	112,31
1678.020	Bio filter ring 10p.	2,30	3115.480	Silencer with hose	7,86
1678.370	PVC hose 6 x 9 mm x 2 m (diam. .23 x .34 x 78.7 in.)	2,69	3130.020	Cover with four slots	3,90
1678.380	PVC hose 6 x 9 mm x 10 m (diam. .23 x .34 x 393.6 in.)	12,57	3130.130	Impeller housing w. nozzel f. Comline	31,01
1678.390	PVC hose 6 x 9 mm x 1 m (diam. 23 x .34 x 39.1 in.)	1,84	3130.160	Nozzle	6,21
1678.400.S	Hose clip	0,88	3130.250	Comline skimmer support	15,83
1678.710.S	Connection for bio	4,03	3130.340	Pressure pipe	2,04
1691.100	Glass housing Kit 16/21	174,27	3130.360	M6 air regulating screw	1,41
1891.100	Glass housing Kit 16/21	174,27	3130.482	Set: 2 hoses+ cap	7,86
2002.000	Turbelle® classic 2002	185,23	3150.110	Switched Socket Outlet 3150.11	46,19
2002.020	Cover	14,79	3150.250	Support for sensor	8,61
2002.100	Motor housing	41,49	3150.300	Sensor w.cinch plug	23,00
2002.110	Motor with cable	75,85	3150.310	Holder board	1,66
2002.220	Rotor	24,07	3155.000	Osmolator Universal	141,25
2002.710	Bio connection for 2002, 4002	9,36	3155.100	Sliding unit for sensor	2,49
3000.010	Motor block for 3000	80,46	3155.200	Sliding unit for level sensor	2,14
3000.015	Motor block	73,17	3155.250	Support f. Osmolator	19,36
3000.020	O-ring seal, 78x2.5mm	1,39	3155.500	Magnet holder for operating sensor	19,50
3000.030	Cooling duct	3,27	3155.600	Magnet holder for two sensors	21,50
3000.040	Upper bearing	1,13	3165.000	Nano Cleaner	55,52
3000.050	Magnetic rotor	11,80	3165.080	Bottom lid for 3165, 9002	2,76
3000.070	Drive shaft	6,61	3165.100	Nano Cleaner housing	29,70
3000.080	Brake shoes 2 pcs.	2,25	3165.400	Outlet pipe with flow deflector	3,61
3000.090	Brake shell + ring	6,65	3166.000	Comline filter.	69,95
3000.092	Brake ring	1,15	3166.020	Sliding cover	3,32
3000.100	Bearing bush	3,22	3166.050	Cup H7A, ø 19mm	1,10
3000.110	Clampring	2,20	3166.060	Cup black ø 9,5mm	1,10
3000.120	Impeller	4,39	3166.070	Retaining plate	3,32
3000.130	Impeller housing	19,13	3166.100	Filter housing	43,16
3000.220	Mounting bar	2,87	3166.200	Comline bell compl.	21,65
3000.225	Elastic ground, 1 pair	0,50	3166.231	Sliding unit Comline holder right	2,15
3000.230	Sliding unit	2,15	3166.232	Sliding unit Comline holder left	2,15
3000.240	Clamp holder	4,67	3166.250	Comline support	11,10
3000.243	Screw set	1,67	3166.280	Pot with handle	15,49
3000.244	Holding device extension	3,02	3166.500	Comline filter	108,50
3000.245	Cable fastener	10,84	3166.760	Tube 19x300	3,91
3000.250	Turbelle® holder	6,92	3167.000	Comline double filter.	133,64
3000.260	Holding device extension	8,59	3167.200	Comline bell complete for 3167	21,65
3000.261	Plate without thread	1,10	3167.500	Comline double filter	163,90
3000.264	2 screws M5x10mm	1,53	3170.000	Comline automatic calcium dispenser	215,88
3000.270	Adhesive attachment for holder	2,20	3170.100	Housing of Calcium Automat	35,70
3000.280	Holding bracket	2,04	3170.134	Connecting unit to 800.040	12,80



Total price list with spare parts - EURO

Art. No.	Designation	Net sales price	Art. No.	Designation	Net sales price
3170.135	Connecting unit to 1073.008	12,80	6055.700	Drive unit for 6055	8,16
3170.200	Reactor of Calcium Automat	102,61	6060.015	Motor block	45,52
3170.300	Reducing adapter and T piece	2,20	6060.120	Hydro propeller	8,25
3170.460	Y branch	4,21	6060.250	Turbelle® holder	10,45
3170.500	Automatic calcium dispenser extension.	62,11	6065.000	Turbelle® stream 6065	94,96
3174.112	Screw cap and seal	5,54	6065.100	Motor block	37,97
3178.710	Bio connection for 3005	8,56	6065.130	Propeller housing	19,13
3179.000	Bio-hydro-reactor	62,11	6065.500	Magnet holder	28,50
3179.020	Sliding cover with cutout	3,32	6065.510	Clamp	7,61
3179.050	Filter mat	4,15	6065.600	Magnet Holder Silence	32,50
3179.100	Housing	35,70	6065.700	Drive unit	15,64
3200.000	Cartridge filter 3200	38,54	6065.792	Disc for drive	1,02
3200.520	Connector	12,62	6080.015	Motor block	80,46
4002.000	Turbelle® classic 4002	217,80	6080.120	Hydro propeller	8,25
4002.020	Cover	16,99	6080.130	Suction housing	31,13
4002.060	Screw M 4x20 V2A	0,80	6080.200	Protective grating	7,80
4002.070	Motor bearer 2 pcs.	4,25	6080.230	Sliding piece with hinge	4,04
4002.080	Retainer 10 pcs.	5,01	6080.250	Holder stabilizer	3,12
4002.090	Fan	5,33	6080.400	Swivel arm	3,12
4002.100	Motor housing	41,45	6080.500	Magnet holder	28,50
4002.110	Motor with cable	93,66	6080.520	Clamp holder	10,00
4002.120	Rubber mount 4 pcs.	4,15	6080.600	Drive unit	23,16
4002.130	Shaft set	8,44	6080.640	Drive shaft	5,71
4002.131	Pinion with spring	4,15	6080.641	Screw M4x16	0,90
4002.200	Shaft housing	12,77	6085.000	Turbelle® stream 6085	125,21
4002.202	Clamping ring	3,47	6085.100	Motor block	64,46
4002.203	Felt strip	1,05	6085.700	Drive unit	18,16
4002.220	Rotor	23,09	6091.000	Wavecontroller	69,05
4002.250	Repair kit	12,71	6100.015	Motor block for 6100/6100A	65,03
4002.260	Motor bearings 2pcs.	16,99	6100.100	Turbelle® stream rep.	160,89
4002.770	Flow deflector	3,84	6100.120	Hydro propeller	12,48
5000.020	Metering pump	15,78	6100.600	Drive unit for 6000/6100/6200	23,48
5000.150.S	Protective grid	6,51	6100.700	Drive unit+ propeller	22,74
5000.240	Hose clamp	1,25	6101.015	Motor block	170,34
5000.300	Sensor w.cinch plug	23,00	6101.240	Power supply unit 12-24V DC	39,78
5000.380	PVC hose 4 x 7 mm x 10 m (diam. .15 x .27 x 393.6 in.)	9,85	6101.241	15 V jumper for 6101.240	1,50
5000.390	PVC hose 4 x 7 mm x 3 m (diam. .15 x .27 x 118.1 in.)	3,45	6101.242	24 V jumper for 6101.240	1,50
5000.430.S	Cap	1,20	6101.243	18 V jumper for 6101.240	1,50
5000.440	Cap	1,07	6101.244	12 V jumper for 6101.240	1,50
5000.500	Holder for 3 sensors	16,79	6105.000	Turbelle® stream 6105	228,57
5000.780.S	Plug in connector	1,65	6105.100	Motor block	123,30
5001.015	Motor block	103,02	6105.500	Safety Connector	35,70
5001.390.S	Silocon hose (12,5cm)	4,37	6105.700	Drive unit	20,48
5002.100	Storage container 13 l (3.4 USgal.)	7,47	6125.000	Turbelle® stream 6125	166,39
5002.250	Storage container 27 l (7.1 USgal.)	14,22	6125.100	Motor block	84,15
5005.000	Turbelle® e-jet 5005	140,72	6125.700	Drive unit	20,48
5005.015	Motor block	73,17	6130.015	Motor block	94,39
5012.010	Power supply unit 11V	13,28	6200.015	Motor block for 6200/6200A	123,81
5016.000	Controller no more available see 5017	105,11	6200.100	Turbelle® stream rep.	218,84
5016.100	Velcro® strips 2x5,5cm (2.1 in.)	0,86	6200.120	Hydro propeller	15,09
5017.000	Controller	105,11	6200.130	Suction housing	36,48
5020.250	Air adjust (chock)	1,34	6200.230	Sliding piece + screw	4,04
5020.300	Sensor w. jack plug	23,00	6200.250	Stream Rock	60,34
5024.010	Filter sponge for 5024	2,20	6200.255	Turbelle® holder	12,75
5024.020	Top cover for 5024,3165	2,76	6200.500	Magnet holder.	40,89
5024.040	Universal pump Mini 5024.04	10,36	6200.509	9 elastic pads f. Magnet Holder	2,20
5024.042	Drive unit for 5024.04	3,51	6200.700	Drive unit + propeller	30,41
5074.000	Calcium dispenser	77,09	6200.800	Transformer 20V/80VA	85,21
5074.010	Non-return valve water	2,60	6201.015	Motor block	226,44
5074.500	Calcium hydroxide - 250 g (.55 lbs.)	7,99	6205.000	Turbelle® stream 6205	363,87
6025.000	Turbelle® nanostream® 6025	43,63	6205.100	Motor block	180,30
6025.100	Motor block	21,98	6205.130	Propeller housing	30,48
6025.130	Propeller housing	8,16	6205.200	Protective grating	8,80
6025.200	Protective grating	6,63	6205.500	Magnet holder	40,89
6025.250	Nanostream® Rock	32,90	6205.600	Magnet Holder Silence	44,89
6025.500	Magnet holder	15,72	6205.700	Drive unit	28,45
6025.510	Clamp	5,61	6206.000	Nano Wavebox	236,97
6025.700	Drive unit	8,16	6206.100	Nano Wavebox housing	38,10
6025.740	Disc for drive	1,02	6206.200	Nano Wavebox pump	106,70
6045.000	Turbelle® nanostream® 6045	63,27	6212.020	Cover with twelve slots	3,90
6045.100	Motor block	30,35	6212.070	Retaining plate	15,42
6045.130	Propeller housing	9,69	6212.200	Protective grating	7,80
6055.000	Turbelle® nanostream® 6055	160,65	6212.300	Sponge-ring	7,62
6055.100	Motor block	86,70	6215.000	Wavebox	399,28
6055.240	Power supply unit 12-24V DC	29,58	6215.015	Motor block	224,00

TUNZE® Total price list with spare parts - EURO

Art. No.	Designation	Net sales price	Art. No.	Designation	Net sales price
6215.100	Wavebox housing	55,00	7079.200	CO2 cylinder - 2.0 kg (4.4 lbs.)	134,44
6215.200	Wavebox pump	240,00	7080.000	Theben-Timer 7080	22,13
6215.300	Foam ring	6,12	7091.000	Singlecontroller	46,74
6215.500	Wavebox extension	355,79	7092.300	Cable 1,2m Multicontroller	12,59
6250.510	O-ring seal 50x6 mm	4,48	7092.340	Y adapter	37,85
6260.015	Motor block	116,23	7094.050	Photo-electric cell	11,92
6260.100	Wavebox pump	202,88	7094.400	Pump adapter	75,60
6261.000	Wavebox pump	242,22	7095.000	Multicontroller	191,04
6261.015	Motor block	184,23	7095.051	Cable clamp 3mm	1,25
6300.130	Suction housing ø63mm	50,41	7096.000	Multicontroller	115,97
6300.240	Power supply unit 24 VDC	127,50	7180.010	Motor block for 7180	63,37
6300.700	Drive unit + propeller	38,45	7180.015	Motor block for 7180/2	63,37
6301.015	Motor block	347,16	7200.200	Transformer 12V/20VA	29,87
6305.000	Turbelle® stream 6305	521,85	7200.600	Drive unit	20,43
6305.100	Motor block	282,44	7210.202	Transformer 12V/20VA	33,00
6305.130	Propeller housing	40,41	7240.000	Turbelle® electronic	151,90
6305.700	Drive unit	28,45	7240.015	Motor block	65,03
7005.140	Calibration solution 600 µS/cm	5,33	7240.245	Button for driver	0,43
7008.000	Reef Excel® Lab Marine Salt, 8kg	22,04	7240.256	angle AL 80x40x15x2	1,91
7008.200	Reef Excel® Lab Marine Salt, 16 kg	45,75	7240.270	Driver	78,03
7008.400	Reef Excel® lab marine salt, 4 x 8kg	89,62	7240/2	Turbelle® electronic	151,90
7008.500	Reef Excel® lab marine salt, 20kg	53,00	7400.610	O-ring seal red	1,10
7010.000	Quick test for nitrate, 100 strips	23,24	7410.120	Impeller	4,39
7011/2	Nitrate measuring box	44,02	7410.602	Transformer (19)20V/65VA	57,25
7012/2	Nitrite measuring box	72,68	7607/2	Water level alarm	136,98
7013.000	Multistick	36,57	8001.000	T8 Osram Lumilux 11 - L 44 cm (17.3 in.), 15 W	9,11
7014/2	Carbonate hardness measuring box	45,77	8002.000	T8 Osram Lumilux 11 - L 59 cm (23.3 in.), 18 W	6,64
7015/2	Calcium measuring box	72,68	8003.000	T8 Osram Lumilux 11 - L 90 cm (35.4 in.), 30 W	10,07
7016.000	Quick test for phosphate	39,56	8004.000	T8 Osram Lumilux11 - L 120 cm (47.2 in.), 36 W	6,09
7016.500	High sensitivity test for phosphate	91,49	8005.000	T8 Osram Lumilux11 - L 150 cm (59 in.), 58 W	10,19
7017/2	Ammonia measuring box	44,98	8006.000	T8 Osram blue 67 - L 59 cm (23.3 in.), 18 W	12,95
7019/2	Iron measuring box	43,60	8007.000	T8 Osram blue 67 - L 90 cm (35.4 in.), 30 W	12,95
7020/2	Total hardness measuring box	28,01	8008.000	T8 Osram blue 67 - L 120 cm (47.2 in.), 36 W	12,95
7028.900	TUNZE® Aquawind	53,04	8009.000	T8 Osram blue 67 - L 150 cm (59 in.), 58 W	12,95
7028.902	Power supply unit	26,20	8016.000	T12 Philips Aqua Coral - L 120 cm (47.2 in.), 40 W	26,48
7028/3	Temperature controller set °C	162,90	8018.000	T12 Philips Aqua Coral - L 59 cm (23.3 in.), 40 W	30,41
7028/3_A	Temperature controller set °F	162,90	8020.000	T12 Philips Aqua Coral - L 150 cm (59 in.), 140 W	38,28
7030.140	Calibration solution 50 mS/cm	5,33	8040.000	HQI bulb 70W/D, 5,200 K, RX7s	41,22
7032/2	Conductivity meter	220,34	8041.000	HIT bulb 70W, 10,000 K, RX7s	82,80
7040.110	pH-buffer, pH 9	5,43	8041.100	HIT bulb 70W, blue, >15 K, RX7s	77,32
7040.115	ph-buffer, pH 5	5,97	8042.000	HQI bulb 150W/D, 5,200 K, RX7s	44,94
7040.117	pH-buffer, ph 7	4,60	8043.000	HIT bulb 150W, 10,000 K, RX7s	49,91
7040.120	Buffer solution for pH 7 and 9	8,71	8043.070	HIT bulb 150W, 14,000 K, RX7s	90,55
7040.130	Buffer solution for pH 5 and 7	8,89	8043.100	HIT bulb 150W, blue, >15K, RX7s	77,32
7040.140	Buffer set pH 5/7/9	14,70	8044.000	HQI bulb 250W/D, 5,200 K, Fc2/18	88,23
7040.200	Cleaning solution	5,33	8045.000	HIT bulb 250W, 10,000 K, Fc2/18	57,27
7040.400	3 m KCl solution 50ml	4,60	8045.070	HIT bulb 250W, 14,000 K, Fc2/18	105,23
7055.100	mV Electrode	124,47	8048.000	HQI bulb 250W, 10,000 K, E40	110,40
7070.010	CO2 non-return valve.	9,44	8049.000	HQI bulb 400W, blue, E40	131,40
7070.012	Glue-in nipple for hose, diam. 4x6 mm (.15x.23 in.)	0,87	8051.000	HIT bulb 400W, 10,000 K, E40	153,53
7070.015	Glue-in nipple 30° for hose, diam. 4x6 mm (.15 x .23 in.)	0,87	8062.000	T5 Osram Daylight - L 54.9 cm (21.6 in.), 24 W	7,83
7070.100	pH Electrode 7070.10	66,25	8063.000	T5 Osram Daylight - L 84.9 cm (33.4 in.), 39 W	7,83
7070.110	pH Electrode 7070.11	74,20	8065.000	T5 Osram Daylight - L 114.9 cm (45.2 in.), 54 W	8,22
7070.250	Wall holder	4,31	8068.000	T5 Osram Daylight - L 144.9 cm (57 in.), 80 W	9,33
7070/2	pH controller	223,84	8072.000	T5 Narva blue 2 - L 54.9 cm (21.6 in.), 24 W	25,00
7071/2	mV controller	254,59	8073.000	T5 Narva blue 2 - L 84.9 cm (33.4 in.), 39 W	27,81
7072.100	pH-Electrode f.7072	94,90	8075.000	T5 Narva blue 2 - L 114.9 cm (45.2 in.), 54 W	29,47
7072.200	Silicon hose 4 x 7 mm x 5 m (diam. 15 x.27 x196.8 in.)	12,58	8078.000	T5 Narva blue 2 - L 144.9 cm (57 in.), 80 W	32,27
7072.300	PVC hose 4 x 6 mm x 5 m (diam. .15 x .23 x 196.8 in.)	3,88	8101.000	T8 reflector, tube L 44 cm (17.3 in.), 15 W	8,38
7073.100	Platinum electrode	132,00	8102.000	T8 reflector, tube L 59 cm (23.2 in.),18 W	9,62
7074.110	Valve Set 7074.11	94,05	8103.000	T12 reflector, tube L 59 cm (23.2 in.), 40 W	10,74
7074.400	12V solenoid valve	68,50	8104.000	T8 reflector, tube L 90 cm (35.4 in.), 30 W	12,12
7074.500	CO2 diffuser	21,64	8105.000	T8 reflector, tube L 120 cm (47.2 in.), 36 W	13,56
7074/2	pH/CO2 controller set	310,37	8106.000	T12 reflector, tube L 120 cm (47.2 in.), 40 W	16,05
7075.120	Switched socket outlet	76,01	8107.000	T8 reflector, tube L 150 cm (59.06 in.), 58 W	16,20
7075/2	mV controller set	319,28	8107.010	2 tube brackets, diam. 26 mm (1.02 in.)	3,49
7077.100	Press. gauche 7077/2 0-250 bar	11,26	8108.000	T12 reflector, tube L 150 cm (59 in.), 140 W	19,25
7077.110	Press. gauche 7077/3 0-250 bar	13,52	8108.010	2 tube brackets, diam. 38 mm (1.49 in.)	4,81
7077.150	Seal ring for 7077.100	1,10	8110.000	T5 reflector, tube L 54.9 cm (21.6 in.), 24 W	11,94
7077.200	Fine adjustment val. 7077/2	11,26	8110.010	2 tube brackets, diam. 16 mm (.62 in.)	3,12
7077.210	Fine adjustment val. 7077/3	12,81	8111.000	T5 reflector, tube L 84.9 cm (33.4 in.), 39 W	13,91
7077.300	Seal ring for 7077/2	2,76	8112.000	T5 reflector, tube L 114.9 cm (45.2 in.), 54 W	10,36
7077.310	Seal ring for 7077/3	2,76	8114.000	T5 reflector, tube L 144.9 cm (57.05 in.), 80 W	17,82
7077/3	Pressure reducer	65,82	8159.011	Ballast 70W for 140W	24,20
7079.150	CO2 cylinder - 1.5 kg (3.3 lbs.)	116,97	8159.012	Starter for 140 W tubes	6,77



Total price list with spare parts - EURO

Art. No.	Designation	Net sales price	Art. No.	Designation	Net sales price
8200.000	Electronic starter 8 - 65 W	14,26	9005.140	Skimmer cup	39,36
8201.000	Screw connection - diam. 26 mm (1.02 in.)	4,37	9005.400	DOC skimmer extension set	36,41
8202.000	Screw connection - diam. 38 mm (1.49 in.)	3,57	9006.000	DOC Skimmer 9006.	192,44
8203.000	Screw connection - diam. 16 mm (.62 in.)	3,57	9006.015	Motor block	40,32
8204.000	Starter Sti 20W	3,13	9006.040	Hydrofoamer	112,31
8205.000	Socket f.tube ø26mm	7,20	9010.015	Motor block	73,17
8215.000	T8 built-in illuminator - ~ 54 cm (21.2 in.), 2x15 W	72,44	9010.040	Hydrofoamer	140,01
8218.000	T8 built-in illuminator - ~ 67.5 cm (26.5 in.), 2x18 W	72,91	9010.100	Housing	86,30
8230.000	T8 built-in illuminator - ~ 97.5 cm (38.3 in.), 2x30 W	92,49	9010.200	Cover for aspirator	7,92
8236.000	T8 built-in illuminator - ~ 128 cm (50.3 in.), 2x36 W	109,91	9010.300	Cover with sliding cover	8,35
8258.000	T8-Built-in illuminator - ~ 158 cm (62.2 in.), 2x58 W	107,88	9010.350	Cap with cover	3,65
8322.000	T5 built-in illuminator - ~ 80 cm (31.4 in.), 2x24 W	128,85	9010.360	Air regulator screw M8	1,53
8323.000	T5 built-in illuminator - ~ 100 cm (39.3 in.), 2x39 W	134,41	9010.400	Sleeve below cover	7,92
8325.000	T5 built-in illuminator - ~ 126 cm (49.6 in.), 2x54 W	142,97	9010.700	Tube with bushing	16,62
8328.000	T5 built-in illuminator - ~ 156 cm (61.4 in.), 2x80 W	216,09	9011.000	DOC Skimmer 9011.	245,38
8441.100	Canopy black	2,76	9011.015	Motor block	73,17
8441.350	Holding dev.f. 8460/-65/-70/-80/-90	36,67	9011.040	Hydrofoamer e-jet	140,01
8441.400	Rope for lamp,2m	2,76	9015.140	Skimmer cup	83,54
8460.000	Lamp - Design 8460	369,21	9016.000	DOC Skimmer 9016.	327,73
8465.000	Lamp - Design 8465	459,00	9020.140	Foam extraction unit	75,43
8470.000	Lamp - Design 8470	860,90	9021.000	DOC Skimmer 9021.	411,76
8480.000	Lamp - Extension 8480	847,32	9206.000	DOC Skimmer 9206.	192,44
8480.002	External Controller 250W,230V/50Hz	251,97	9211.000	DOC Skimmer 9211.	243,70
8480.004	External Controller 400W,230V/50Hz	276,13	9400.040	Hydrofoamer	201,96
8490.000	Lamp - Extension 8490	878,54	9400.041	Motor block with O ring seal	120,00
8512.100	Carbon / sediment filter S	21,54	9400.042	Cover with O ring seal and nozzle	12,18
8515.000	Nano RO station	81,42	9400.043	Pump housing	24,23
8515.070	Preliminary filter with O-ring seal	10,00	9400.046	Ceramic shaft with holder	4,16
8515.080	Carbon Block O-ring seal	2,50	9400.047	Complete drive unit with shaft	28,56
8515.120	Carbon Block Filter	7,27	9400.048	Silencer with hose	7,80
8515.500	Thin-film composite membrane	47,05	9410.000	DOC Skimmer 9410	277,50
8515.520	Capillary for 8515	13,07	9410.040	Hydrofoamer Silence	107,56
8515.701	Metric adapter	7,16	9410.041	Motor block with screw	65,50
8515.702	Angle for RO tube	4,90	9410.047	Drive unit with bearing.	15,67
8522.100	Sediment fine filter L	11,33	9410.048	Silencer with hose	7,80
8522.120	Carbon sediment filter 5µm	8,46	9410.200	Post-filter bag	10,63
8532.010	1/4" nylon nipple	3,90	9410.241	Housing	80,25
8532.020	1/4 in. elbow for reverse osmosis hose	3,94	9410.250	Disc	10,59
8532.021	Clamp for RO connection	1,10	9410.300	Outlet pipe155mm (6.1 in.)	3,90
8532.030	1/8 in. elbow for reverse osmosis hose	4,41	9410.400	Adapter ring for 9410.	2,29
8532.040	1/8 in. junction for hose 6.3 mm (.24 in.)	4,90	9410.500	Post-filter	23,19
8532.050	Pressure gauge 1/8"	12,20	9420.000	Master DOC Skimmer 9420.000	583,53
8532.060	Screw 3,2x17mm Kogapur	0,22	9420.040	Hydrofoamer Silence	132,77
8532.070	O-ring seal for membrane housing	2,25	9420.041	Motor block with screw	75,00
8532.080	O-ring seal for filter housing	3,86	9420.042	Cover with O ring seal and nozzle	12,20
8532.090	1/4" - 1/8" nylon nipple	3,46	9420.043	Screw for Motor block	0,55
8533.000	RO TDS Monitor	63,62	9420.045	Hose clip	3,80
8533.100	T-piece	6,30	9420.046	Cooling duct	2,90
8550.000	RO station.	158,90	9420.047	Drive unit with bearing	19,67
8550.010	Wrench for 8550	4,90	9420.048	Silencer with hose	7,80
8550.020	1/4 in. junction for reverse osmosis hose	3,62	9420.211	Skimmer cup	97,74
8550.090	1/4" connector with RO pipe	5,16	9420.231	Skimmer cup lid	60,51
8550.100	Carbon sediment filter .5 µm	10,23	9420.241	Housing	160,35
8550.120	Sediment filter 20 µm	7,25	9420.250	Disc	14,59
8550.501	Mixed Bed Ion Exchanger	15,30	9420.260	Angle 90 deg.	7,90
8550.510	Spare membrane for 8550	67,12	9420.300	Outlet pipe 220 mm (9 in.)	3,90
8550.520	Capillary 25% rate 60S/M/L	8,63	9420.380	Outlet fleece, 1 ea.	3,20
8550.530	Capillary for 8550	4,56	9420.400	Booster-Ring	2,29
8550.600	RO Ion Exchanger	38,30	9440.000	Master DOC Skimmer 9440.000	716,30
8550.602	Clip for 8550.600	5,72	9440.300	Outlet pipe 120 mm (4.7 in.)	3,42
8552.500	Membrane Kogapur 90S/M/L	80,92	9460.000	Master DOC Skimmer 9460.000	1339,20
8552.520	Capillary 25% rate 90S/M/L	8,63	9460.211	Skimmer cup	300,00
8554.520	Capillary 25% rate 150/M/L	8,63	9460.231	Skimmer cup lid	87,87
8555.000	RO water controller	139,95	9460.241	Housing	518,57
8555.100	Controller 8555	64,42	9460.250	Disc	28,02
8555.200	Water valve	59,00	9460.300	Outlet pipe 280 mm (11 in.)	5,84
8556.000	Reverse osmosis pressure hose /1m	2,79	9480.000	Master DOC Skimmer 9480.000	1471,97
8557.000	3/4 in. screw connection	12,54	9480.300	Outlet pipe 240 mm (9.4 in.)	4,07
9002.000	DOC Skimmer 9002	107,45			
9002.030	Upper lid	6,64			
9002.100	Housing for 9002	37,30			
9002.250	Nano holder	8,47			
9002.400	Outlet pipe with nozzle	10,99			
9005.015	Motor block	40,32			
9005.040	Hydrofoamer	112,31			

END